

GUJARAT TECHNOLOGICAL UNIVERSITY

BE - SEMESTER-VI(NEW) – EXAMINATION – SUMMER 2019

Subject Code:2161901

Date:27/05/2019

Subject Name:Dynamics of Machinery

Time:10:30 AM TO 01:00 PM

Total Marks: 70

Instructions:

1. Attempt all questions.
2. Make suitable assumptions wherever necessary.
3. Figures to the right indicate full marks.

MARKS

- Q.1**
- (a) Justify, “In case of dynamic balancing system, minimum two balancing masses are required for the balancing of the system”. **03**
- (b) Define the terms: (i) Natural frequency, (ii) damping, (iii) static balancing, (iv) forced vibration. **04**
- (c) A line shaft carries five pulleys A, B, C, D and E, equally spaced along the shaft. The masses of the pulleys A, C and D are 10 Kg, 8 Kg and 16 Kg respectively. The eccentricity of all pulley masses can be assumed equal. The angular distance between A & C is 90° and C & D is 135° measured in the same direction. Find the masses of pulleys B and E and their angular position, so that the shaft is completely balanced. **07**
- Q.2**
- (a) What is vibration isolation? Discuss in brief different material used for vibration isolation. **03**
- (b) A machine weighing 20 Kg is supported on two slabs of isolators, natural rubber and felt as shown in figure 2.1. K & C represents stiffness and damping coefficients of the respective materials. Find the undamped and damped natural frequencies of the system in vertical direction. Neglect the mass of the isolators. **04**

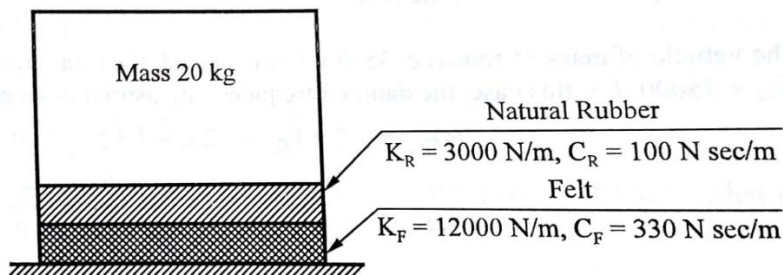

Figure: 2.1

- (c) A six-cylinder four stroke vertical in-line engine has a firing order of 1-4-5-2-3-6. Firing takes place with equal angular interval. The mass of reciprocating parts per cylinder is 2 Kg, stroke 100 mm and connecting rod length 200 mm. The cylinder center lines are spaced at 300 mm apart. The crank shaft speed is 300 rpm. Examine the engine for the balance of primary and secondary forces and couples. **07**
- OR**
- (c) Determine the natural frequency of the mass $m = 15$ Kg as shown in figure 2.2. Assuming that the cords do not stretch and slide over the pulley rim. Assume that the pulley has no mass. Take $K_1 = 8000$ N/m and $K_2 = 6000$ N/m. **07**

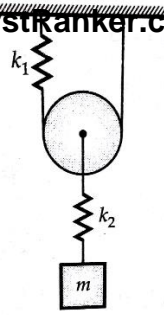

Figure 2.2

- Q.3** (a) What is damping factor. What is the role of damping factor in the vibrations. **03**
 (b) A body of mass 1000 kg is suspended on a leaf spring. The system is then vibrated and its natural frequency when measured is 7 rad/sec. It is observed that if the initial amplitude is 48 mm, the subsequent amplitudes are 40 mm and 32 mm. determine the springs stiffness and the Coulombs damping force. **04**
 (c) In a spring mass system, a mass of 100 kg is attached with the spring of stiffness 30 KN/m. The damping provided is only the 25 % of the critical value. Determine (i) the damping ratio, (ii) the critical damping coefficient, (iii) the natural frequency of damped vibrations, (iv) the logarithmic decrement, (v) the ratio of two successive amplitudes. **07**

OR

- Q.3** (a) Give any 3 examples of each where vibration is desirable and undesirable. **03**
 (b) Derive an expression for absolute amplitude. **04**
 (c) An electric motor is supported on a spring and a dashpot. The spring has the stiffness 6400 N/m and the dashpot offers resistance of 500 N at 4.0 m/s. The unbalanced mass 0.5 kg rotates at 5 cm radius and the total mass of vibratory system is 20 kg. The motor runs at 400 rpm. Determine (i) damping factor, (ii) amplitude of vibration and phase angle, (iii) resonant speed and resonant amplitude. **07**

- Q.4** (a) Explain method of static balancing of rotating masses. **03**
 (b) Explain torsional vibration of geared system. **04**
 (c) A rotor having a mass of 5 kg is mounted midway on a simply supported shaft of diameter 10 mm and length 400 mm. The CG of the rotor is 0.02 mm away from the geometric center of the rotor due of manufacturing tolerances. If the rotor rotates at 3000 rpm, find the amplitude of steady state vibrations and dynamic force transmitted to the bearings. Neglect the effect of damping. Take $E = 2 \times 10^{11} \text{ N/mm}^2$. **07**

OR

- Q.4** (a) Write a short note on Jump phenomenon in cam. **03**
 (b) Derive an expression for critical speed of shaft carrying a single rotor and having no damping. **04**
 (c) Two identical rotors are attached to the two ends of a stepped shaft as shown in figure 4.1. Each rotor weighs 450 kg and has radius of gyration of 0.38 m. The total length of the shaft is 0.6 m. find the frequency of free torsional vibration of the system and the position of the node from either mass. Assume modulus of rigidity as $80 \times 10^9 \text{ N/m}^2$. **07**

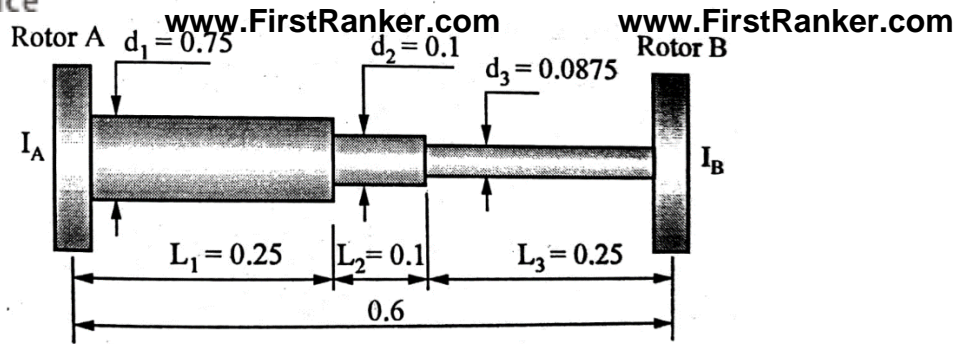

Figure 4.1 (All units in "m")

- Q.5** (a) What is swaying couple? Derive an expression for swaying couple. **03**
- (b) A torsional pendulum when immersed in oil indicates its natural frequency as 200 Hz. But when it was put to vibrate in vacuum having no damping, its natural frequency was observed as 250 Hz. Find the value of damping factor of the oil. **04**
- (c) Three cylinders of an air compressor have their axes at 120° to one another and their connecting rods are coupled to a single crank. The stroke is 100 mm and length of each connecting rod is 150 mm. The weight of the reciprocating parts per cylinder is 15 N. Find the maximum primary and secondary forces acting on the frame of the compressor when running at 3000 rpm. Describe clearly a method by which such forces may be balanced. **07**
- OR**
- Q.5** (a) Discuss in brief frequency measuring instruments. **03**
- (b) Justify, "Reciprocating masses are partially balanced". **04**
- (c) A mass weighing 1.93 kg is suspended in a box by vertical spring whose constant is 10 KN/m. The box is placed on the top of a shake table producing a vibration $x = 0.09 \sin 8t$. Find the absolute amplitude of mass. Assume no damping. **07**

www.FirstRanker.com