

Code No: RT21013

R13

SET - 1

II B. Tech I Semester Supplementary Examinations, June - 2015
STRENGTH OF MATERIALS - I
(Civil Engineering)

Time: 3 hours

Max. Marks: 70

- Note: 1. Question Paper consists of two parts (**Part-A** and **Part-B**)
2. Answer **ALL** the question in **Part-A**
3. Answer any **THREE** Questions from **Part-B**

PART- A

1. a) The external and internal diameters of an aluminium tube are 30 mm and 25 mm respectively. The yield stress for aluminium is $\sigma_y = 270 \text{ N/mm}^2$. Determine the maximum axial load that can be carried by the tube.
- b) Draw S.F.D & B.M.D for a cantilever carrying a load whose intensity varies uniformly from zero at the fixed end to W per unit run at the free end.
- c) What are the assumptions considered in the theory of pure bending.
- d) Draw the shear stress distribution for rectangular, T, hollow circle cross sections.
- e) State Mohr's theorems
- f) Describe the limitations of thin cylinders when applied to pressure vessels.

(4M+4M+3M+4M+3M+4M)

PART -B

2. A copper flat measuring 60 mm × 30 mm is brazed to another 60 mm × 60 mm mild steel flat as shown in Figure 1. If the combination is heated through 120°C, determine
 - i) The stress produced in each of the bar
 - ii) Shear force which tends to rupture the brazing, and
 - iii) Shear stress.

Take : $\alpha_c = 18.5 \times 10^{-6} \text{ per}^0 \text{ C}$;
 $\alpha_s = 12 \times 10^{-6} \text{ per}^0 \text{ C}$;
 $E_c = 110 \text{ GN/m}^2$;
 $E_s = 220 \text{ GN/m}^2$;

Length of each flat = 400 mm

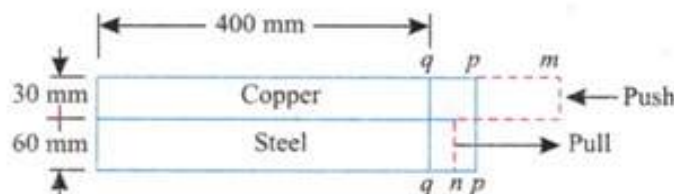

Figure 1

3. A simply supported beam AB of span 10 m carries a U.D.L. of 20 N per metre over 3 metres from L.H support and also over 4 m from the R.H. supports. It has also two isolated loads of 20 N and 60 N at 3 m and 8 m respectively from the L.H. support. Draw the B.M. and S.F. diagrams and calculate the B.M. at significant points.

Code No: RT21013

R13

SET - 1

4. The beam section shown in Figure 2, is subjected to a shear force of 35 kN. Sketch the shear stress distribution for the section.

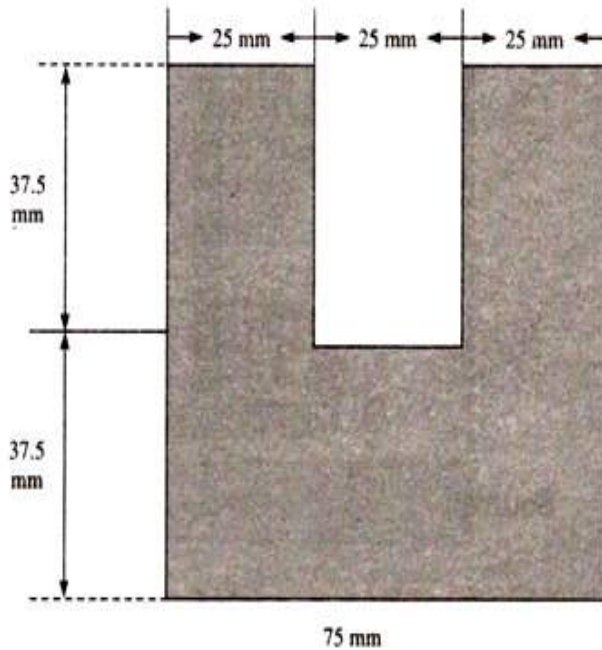

Figure 2

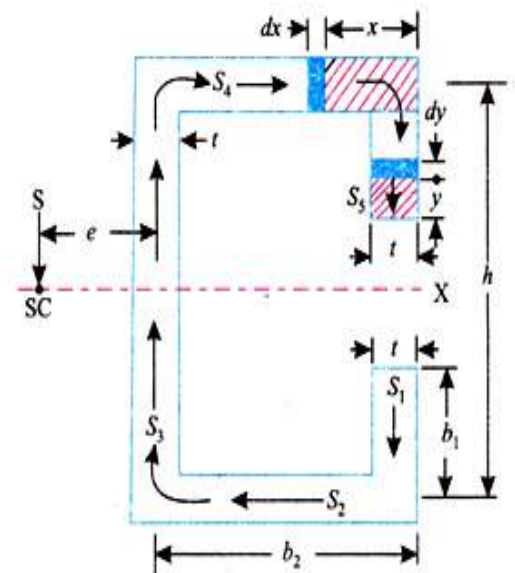

Figure 3

5. Find the shear centre of the section shown in Figure 3.
6. A beam is 10 m long and is simply supported at the ends. It carries concentrated loads of 100 kN and 60 kN at distances of 2 m and 5 m respectively from the left end. Calculate the deflection under each load. Find also the maximum deflection. Take $I = 18 \times 10^8 \text{ mm}^4$ and $E = 200 \text{ kN/mm}^2$
7. A cylinder 250 mm in diameter has a wall thickness of 5 mm and is full of a fluid at atmospheric pressure. Its ends are closed by rigid plates and an axial compressive force of 80 kN is applied to the cylinder so that the pressure of the fluid rises by 90 kPa. Calculate the bulk modulus of the fluid. Take for the cylinder material $E = 200 \text{ kN/mm}^2$ and $\frac{1}{m} = 0.25$



Code No: RT21013

R13

SET - 2

II B. Tech I Semester Supplementary Examinations, June - 2015
STRENGTH OF MATERIALS - I
(Civil Engineering)

Time: 3 hours

Max. Marks: 70

- Note: 1. Question Paper consists of two parts (**Part-A** and **Part-B**)
2. Answer **ALL** the question in **Part-A**
3. Answer any **THREE** Questions from **Part-B**

PART- A

1. a) A load of 4000 N has to be raised at the end of a steel wire. If the unit stress in the wire must not exceed 80 N/mm^2 what is the minimum diameter required? What will be the extension of 3.50 metre length of wire? Take $E = 2 \times 10^5 \text{ N/mm}^2$.
- b) Draw S.F.D & B.M.D for a simply supported beam carrying a load whose intensity varies uniformly from zero at each end to W per unit run at the mid span.
- c) A steel plate is bent into a circular arc of radius 10 meters. If the plate section be 120mm wide and 20 mm thick, find the maximum stress induced and the bending moment which can produce this stress. Take $E = 2 \times 10^5 \text{ N/mm}^2$.
- d) Define shear centre and the principle involved in locating the shear centre.
- e) A cantilever of length l is subjected to a couple M at its free end. Find the slope and deflection of the end.
- f) A seamless pipe 800 mm diameter contains a fluid under a pressure of 2 N/mm^2 . If the permissible tensile stress be 100 N/mm^2 , find the minimum thickness of the pipe.

(4M+4M+4M+3M+3M+4M)

PART -B

2. A composite bar made up of aluminium and steel is held between two supports as shown in Figure 1. The bars are stress – free at a temperature of 40°C . What will be the stresses in the two bars when the temperature is 20°C if (i) the supports are non-yielding, and (ii) the supports come nearer to each other by 0.1 mm. It can be assumed that the change of temperature is uniform all along the length of the bar.

Take : $E_s = 210 \text{ GN/m}^2$;
 $E_a = 74 \text{ GN/m}^2$;
 $\alpha_s = 11.7 \times 10^{-6} \text{ per}^\circ\text{C}$;
 $\alpha_a = 23.4 \times 10^{-6} \text{ per}^\circ\text{C}$;

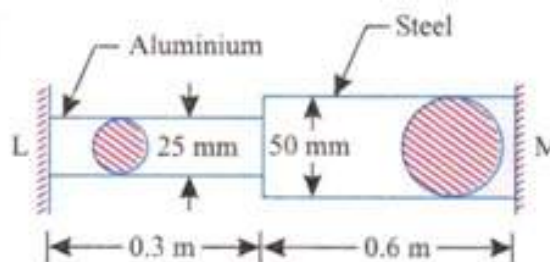

Figure 1



Code No: RT21013

R13

SET - 2

- A horizontal beam 6 m long is freely supported at its ends and carries a vertical load of 1000 N at a distance of 4 m from L.H. end. At a section 2 m from L.H. end, a clockwise couple of 2000 N-m is applied, the axis of the couple being horizontal and perpendicular to the longitudinal axis of the beam. Draw S.F. and B.M. diagrams indicating on them the principal dimensions
- For the section shown in Figure 2, determine the shearing stresses at A, B, C and D for a shearing force of 200 kN and find the ratio of the maximum to mean shear stresses.

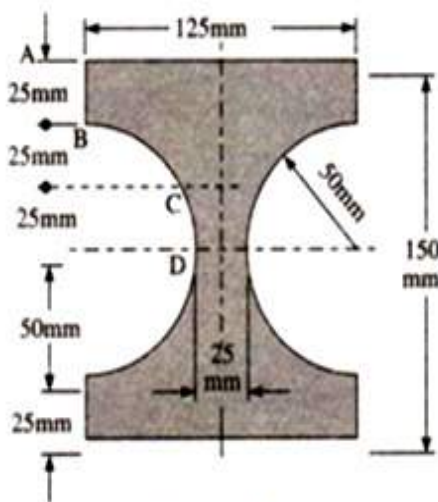

Figure 2

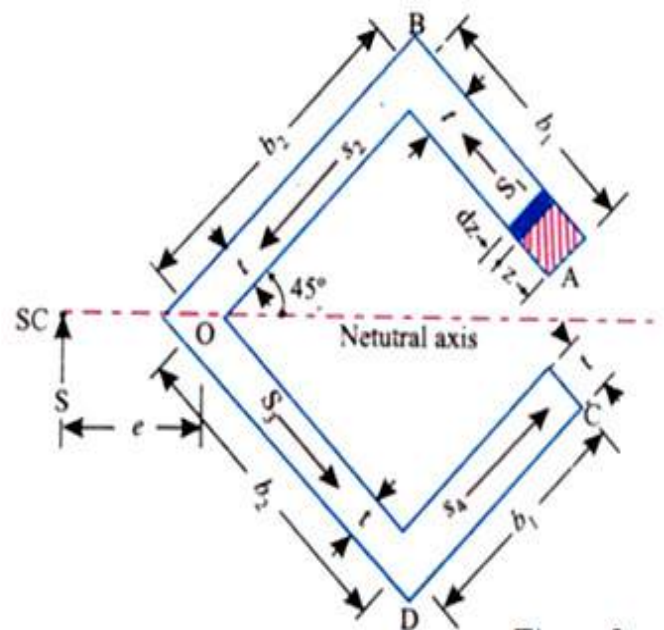

Figure 3

- Locate the shear centre of the section shown in Figure 3.
- A simply supported beam of span l carries a downward point load P at the centre and an upward point load P at a distance $\frac{l}{4}$ from the right end.
Determine (a) The slopes at the ends of the beam
(b) The deflections at the sections where the loads are applied
(c) The maximum downward deflection
- A shell 3.25 meters long, 1 meter in diameter is subjected to an internal pressure of 1 N/mm^2 . If the thickness of the shell is 10 mm, find the circumferential and longitudinal stresses. Find also the maximum shear stress and the changes in the dimensions of the shell.
Take $E = 2 \times 10^5 \text{ N/mm}^2$ and $\frac{1}{m} = 0.3$



Code No: RT21013

R13

SET - 3

II B. Tech I Semester Supplementary Examinations, June - 2015
STRENGTH OF MATERIALS - I
(Civil Engineering)

Time: 3 hours

Max. Marks: 70

- Note: 1. Question Paper consists of two parts (**Part-A** and **Part-B**)
2. Answer **ALL** the question in **Part-A**
3. Answer any **THREE** Questions from **Part-B**

PART- A

1. a) A hollow circular mild steel column of external diameter 300 mm and internal diameter 250 mm carries an axial load of 1500 kN. Determine the compressive stress in the column. Take $E = 2 \times 10^5 \text{ N/mm}^2$.
 - b) Draw the S.F.D & B.M.D of a beam of length $(l+2a)$ has supports 'l' apart with an overhang 'a' on each side. The beam carries concentrated load w at each end.
 - c) Derive the section moduls of a hollow rectangular section.
 - d) What is the consistency of the bending moment on shearing stress, Illustrate with an example.
 - e) A 500 mm long and 5 mm thick strip of steel is subjected to end couples M_0 . The central deflection is found to be 6.25 mm. Find the longitudinal normal strain at the top surface of the strip.
 - f) A 900 mm diameter pipe contains a fluid at a pressure of 25 N/mm^2 . If the safe stress in tension is 100 N/mm^2 find the minimum thickness of the pipe.
- (4M+4M+4M+3M+4M+3M)

PART -B

2. A flat bar of aluminium alloy 25 mm wide and 5 mm thick is placed between two steel bars each 25 mm wide and 10 mm thick to form a composite bar 25 mm \times 25 mm as shown in figure. The three bars are fastened together at their ends when the temperature is 15°C . Find the stress in each of the materials when the temperature of the whole assembly is raised to 55°C . If at the new temperature a compressive load of 30 kN is applied to the composite bar what are the final stresses in steel and alloy?

Take : $E_s = 200 \text{ GN/m}^2$;
 $E_{al} = \frac{200}{3} \text{ GN/m}^2$;
 $\alpha_s = 1.2 \times 10^{-5} \text{ per}^\circ\text{C}$;
 $\alpha_{al} = 2.3 \times 10^{-5} \text{ per}^\circ\text{C}$;

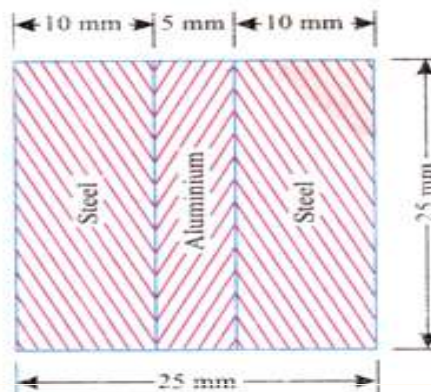

Figure 1



Code No: RT21013

R13

SET - 3

3. A simply supported beam carries inclined loads of 100, 200 and 300 N inclined at 30° , and 45° and 60° to the vertical as shown in Figure 2. The loads act at 1 metre, 2 metres and 3 metres from the left support respectively. If the span is 4 meters, draw the bending moment and shear force diagrams and calculate their values under the loads.

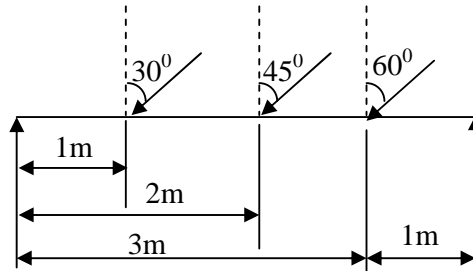

Figure 2

4. A horizontal beam of the section shown in Figure 3, is 3 and 4 meters long and is simply supported at the ends. Find the maximum uniformly distributed load it can carry if the compressive and tensile stresses must not exceed 60 N/mm^2 and 30 Nmm^2 respectively. Draw a diagram showing variation of stress over the mid span section of the beam.

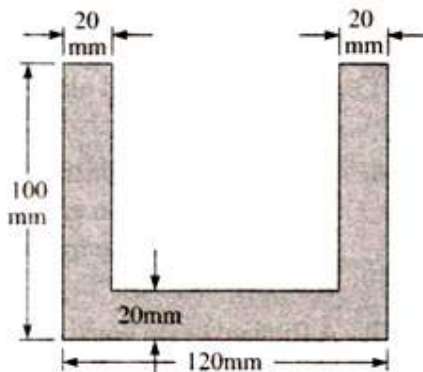

Figure 3

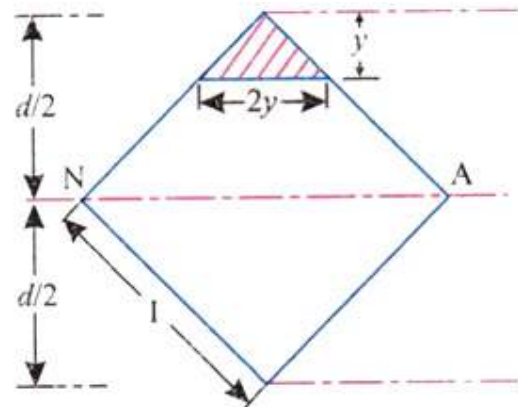

Figure 4

5. A beam of square section subject to a shear force S is so placed that one of its diagonals is horizontal. Sketch shear stress distribution for the section. Refer for Figure. 4
6. Figure 5 shows a simply supported steel beam AB of span 6 m carrying a uniformly distributed load of 60 kN/m on the part CB. The beam is ISWB having $I_{xx} = 9821.6 \text{ cm}^4$. Determine (i) The slopes at A and B, (ii) Deflection at C, (iii) Maximum deflection Take $E = 200 \text{ kN/mm}^2$

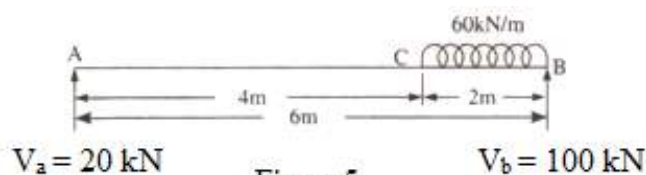

Figure 5

7. A thick spherical shell of 100 mm internal diameter is subjected to an internal fluid pressure of 30 N/mm^2 . If the permissible tensile stress is 80 N/mm^2 , find the thickness of the shell.



Code No: RT21013

R13

SET - 4

II B. Tech I Semester Supplementary Examinations, June - 2015
STRENGTH OF MATERIALS - I
(Civil Engineering)

Time: 3 hours

Max. Marks: 70

- Note: 1. Question Paper consists of two parts (**Part-A** and **Part-B**)
2. Answer **ALL** the question in **Part-A**
3. Answer any **THREE** Questions from **Part-B**

PART- A

1. a) Draw and explain the stress strain diagram for a mild steel subjected to a tensile test.
- b) What are the properties of S.F & B.M diagrams.
- c) Derive the maximum stress of a hollow circular section with external diameter D and internal diameter d.
- d) Where the maximum shear stress occurs in an I – section.
- e) Derive the deflection from bending equation.
- f) How the compressive and tensile stresses varies due to internal pressure in compound cylinders. (4M+4M+4M+3M+4M+3M)

PART -B

2. Two bars A and B of variable diameter as shown in the figure below are made of the same material. The bar A receives an axial blow which produces a maximum stress of 20 kN/cm². Determine the maximum stress produced by the same blow on bar B. If the bar B is also stressed to 20 kN/cm², determine the ratio of strain energies stored in the bar A and B.

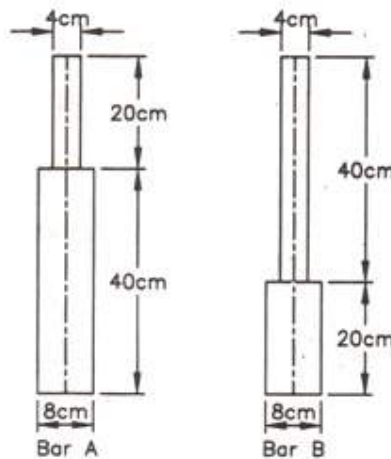

3. A simple beam of span 6 meters carries a distributed load which increases uniformly from zero at the left hand support to a maximum intensity of 4 kN per meter run at the right hand support. Find the distance from the left support of the section which has a maximum B.M.

Code No: RT21013

R13**SET - 4**

- A beam 7 meters long supported at two points equidistant from the ends is loaded with a uniformly distributed load of w Newton per meter run. Calculate the length of the overhang on each side, if the maximum bending moment for the beam has the least value. If the beam is an I – section $100\text{ mm} \times 250\text{ mm}$ overall, with 20 mm thick flange and web and the maximum bending stress is limited to 120 N/mm^2 , find the value of w .
- Calculate the ratio of maximum to mean shear stress in an I – beam, 200 mm wide \times 350 mm deep, having the flanges 25 mm thick and web 12.5 mm thick. Also find the percentage of the total shearing force carried by the web.
- Find the deflection at C in the beam loaded as shown in figure. Take $EI = 10,000\text{ kN} - \text{m}^2$

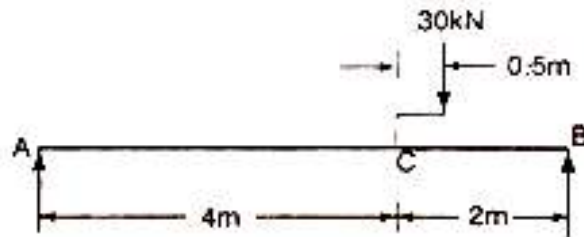

- A compound tube is composed of a tube 250 mm internal diameter and 25 mm thick shrunk on a tube of 250 mm external diameter and 25 mm thick. The radial pressure at the junction is 8 N/mm^2 . The compound tube is subjected to an internal fluid pressure of 84.5 N/mm^2 . Find the variation of the hoop stress over the wall of the compound tube.