

Code No: 07A3EC12

R07**Set No. 2**

II B.Tech I Semester Examinations, MAY 2011
SIGNALS AND SYSTEMS
 Common to BME, ETM, E.CONT.E, EIE, ECE

Time: 3 hours

Max Marks: 80

Answer any FIVE Questions
 All Questions carry equal marks

1. (a) State and Prove Properties of cross correlation function.
 (b) If $v(f) = AT \frac{\sin 2\pi fT}{2\pi fT}$ find the energy contained in $V(t)$. [8+8]
2. (a) Obtain the Trigonometric Fourier series for the function $f(t)$ as shown in figure 6a

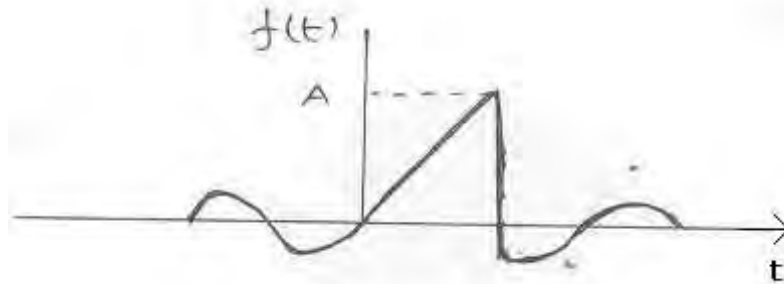

Figure 6a

- (b) Use the definition of the Fourier series to determine the time domain representation signals represented by the following Fourier series coefficients.
 - i. $C_n = j\delta(n+1) - j\delta(n-1) + j\delta(n-3) + j\delta(n+1)$ and $\omega_0 = 4\pi$
 - ii. $C_n = \left(-\frac{1}{5}\right)^{|n|}$, $\omega_0 = 1$. [8+8]
3. (a) When is a function $f(t)$ is said to be laplace transformable.
 (b) What do you mean by region of convergence?
 (c) List the advantages of Laplace transform.
 (d) If $\delta(t)$ is a unit impulse function find the laplace transform of $d^2/dt^2 [\delta(t)]$. [4+4+4+4]
4. (a) Determine the Nyquist rate corresponding to each of the following signals.
 - i. $x(t) = 1 + \cos 2000 \pi t + \sin 4000 \pi t$
 - ii. $x(t) = (\sin 4000 \pi t) / \pi t$
- (b) The signal, $Y(t)$ is generated by convolving a band limited signal $X_1(t)$ with another band limited signal $X_2(t)$ that is
 $Y(t) = X_1(t) * X_2(t)$
 Where,
 $X_1(j\omega) = 0$ for $|\omega| > 1000\pi$
 $X_2(j\omega) = 0$ for $|\omega| > 2000\pi$
 Impulse train sampling is performed on $y(t)$ to obtain

Code No: 07A3EC12

R07

Set No. 2

$$y_p(t) = \sum_{n=-\infty}^{\infty} y(nT) \delta(t - nT)$$

Specify the range of values for sampling period T which ensures that $y(t)$ is recoverable from $Y_p(t)$. [8+8]

5. (a) Find the Z transform of $t^2 e^{-at}$.
 (b) Find the final value and initial value of $x(n)$ for $X(z) = \frac{z^2}{(z-1)(z-0.2)}$. [8+8]
6. (a) Find the Fourier Transform for the following functions shown in figure 1a.

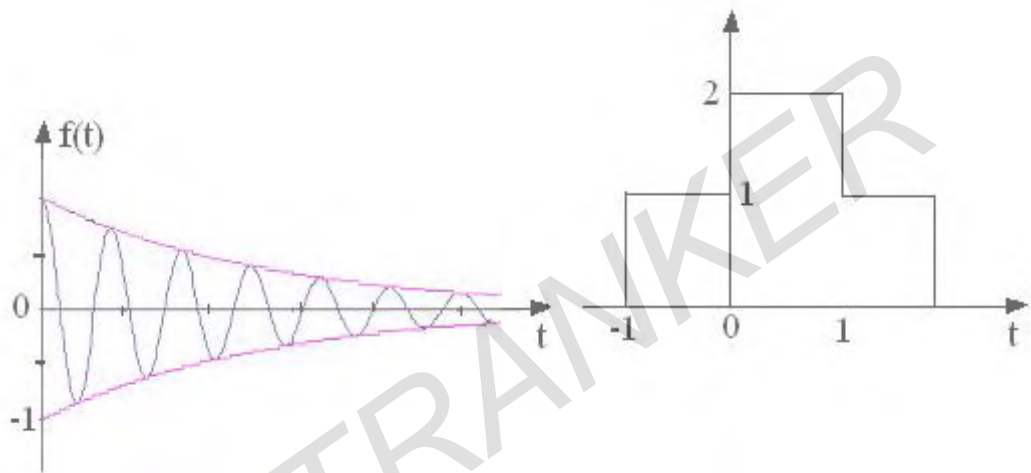

Figure 1a

- (b) Find the total area under the function $g(t) = 100 \sin c((t-8)/30)$. [10+6]
7. (a) Explain the Graphical Evaluation of a component of one function in other function.
 (b) Sketch the single sided and double sided spectra of the following signal:
 $x(t) = 4 \sin(10\pi t - \frac{\pi}{6})$. [10+6]
8. (a) The transfer function of an ideal low pass filter is given by
 $H(j\omega) = KG_w(\omega) e^{-j\omega t_0}$
 Evaluate the unit step response of this filter.
 (b) Find the output voltage $V(t)$ of a network shown in figure 7b. when the voltage applied to the terminals ab is given by $t e^{-t} u(t)$

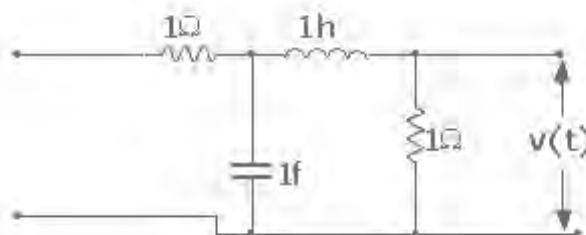

Figure 7b

Code No: 07A3EC12

R07**Set No. 4**

II B.Tech I Semester Examinations, MAY 2011
SIGNALS AND SYSTEMS
 Common to BME, ETM, E.CONT.E, EIE, ECE

Time: 3 hours

Max Marks: 80

Answer any FIVE Questions
 All Questions carry equal marks

1. (a) State and Prove Properties of cross correlation function.
 (b) If $v(f) = AT \frac{\sin 2\pi fT}{2\pi fT}$ find the energy contained in $V(t)$. [8+8]
2. (a) When is a function $f(t)$ is said to be laplace transformable.
 (b) What do you mean by region of convergence?
 (c) List the advantages of Laplace transform.
 (d) If $\delta(t)$ is a unit impulse function find the laplace transform of $d^2/dt^2 [\delta(t)]$. [4+4+4+4]
3. (a) Explain the Graphical Evaluation of a component of one function in other function.
 (b) Sketch the single sided and double sided spectra of the following signal:
 $x(t) = 4 \text{Sin} (10\pi t - \frac{\pi}{6})$. [10+6]
4. (a) Determine the Nyquist rate corresponding to each of the following signals.
 i. $x(t) = 1 + \cos 2000 \pi t + \sin 4000 \pi t$
 ii. $x(t) = (\sin 4000 \pi t) / \pi t$
 (b) The signal, $Y(t)$ is generated by convolving a band limited signal $X_1(t)$ with another band limited signal $X_2(t)$ that is
 $Y(t) = X_1(t) * X_2(t)$
 Where,
 $X_1(j\omega) = 0 \text{ for } |\omega| > 1000\pi$
 $X_2(j\omega) = 0 \text{ for } |\omega| > 2000\pi$
 Impulse train sampling is performed on $y(t)$ to obtain
 $y_p(t) = \sum_{n=-\infty}^{\infty} y(nT) \delta(t - nT)$
 Specify the range of values for sampling period T which ensures that $y(t)$ is recoverable from $Y_p(t)$. [8+8]
5. (a) Find the Z transform of $t^2 e^{-at}$.
 (b) Find the final value and initial value of $x(n)$ for $X(z) = \frac{z^2}{(z-1)(z-0.2)}$. [8+8]
6. (a) The transfer function of an ideal low pass filter is given by
 $H(j\omega) = KG_w(\omega) e^{-j\omega t_0}$
 Evaluate the unit step response of this filter.

Code No: 07A3EC12

R07

Set No. 4

- (b) Find the output voltage $V(t)$ of a network shown in figure 7b. when the voltage applied to the terminals ab is given by $t e^{-t} u(t)$

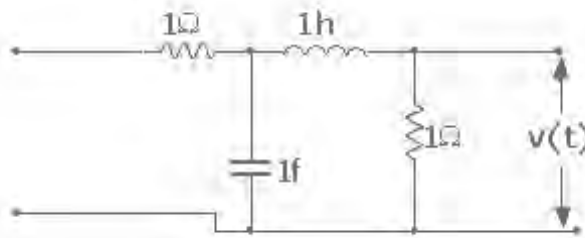

Figure 7b

7. (a) Find the Fourier Transform for the following functions shown in figure 1a.

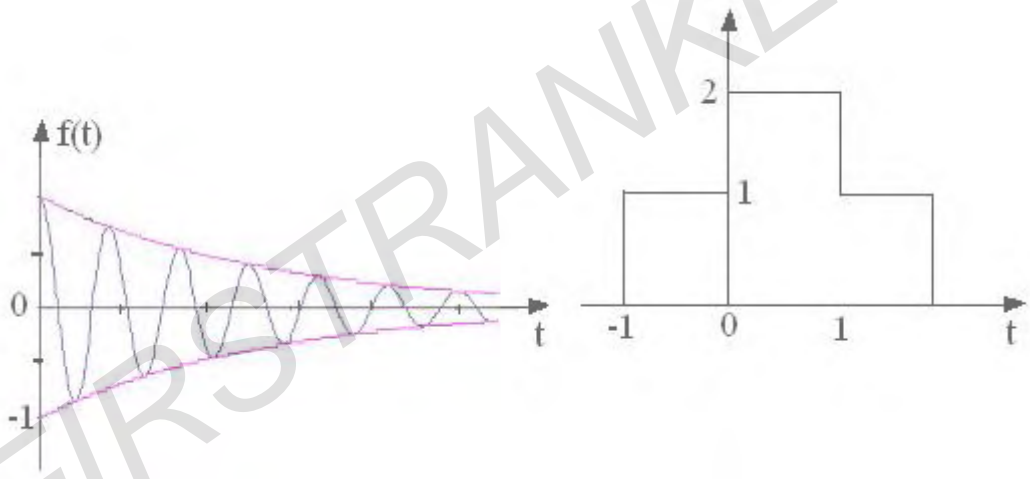

Figure 1a

- (b) Find the total area under the function $g(t) = 100 \sin c((t-8)/30)$. [10+6]
8. (a) Obtain the Trigonometric Fourier series for the function $f(t)$ as shown in figure 6a

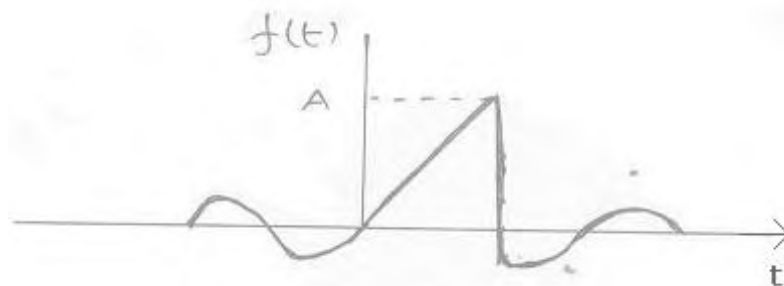

Figure 6a

- (b) Use the definition of the Fourier series to determine the time domain representation signals represented by the following Fourier series coefficients.
- $C_n = j\delta(n+1) - j\delta(n-1) + j\delta(n-3) + j\delta(n+1)$ and $\omega_0 = 4\pi$
 - $C_n = (-\frac{1}{5})^{|n|}$, $\omega_0 = 1$. [8+8]

Code No: 07A3EC12

R07

Set No. 4

FIRSTRANKER

Code No: 07A3EC12

R07**Set No. 1**

II B.Tech I Semester Examinations, MAY 2011
SIGNALS AND SYSTEMS
 Common to BME, ETM, E.CONT.E, EIE, ECE

Time: 3 hours

Max Marks: 80

Answer any FIVE Questions
 All Questions carry equal marks

- The transfer function of an ideal low pass filter is given by $H(j\omega) = KG_w(\omega)e^{-j\omega t_0}$
Evaluate the unit step response of this filter.
 - Find the output voltage $V(t)$ of a network shown in figure 7b. when the voltage applied to the terminals ab is given by $t e^{-t} u(t)$

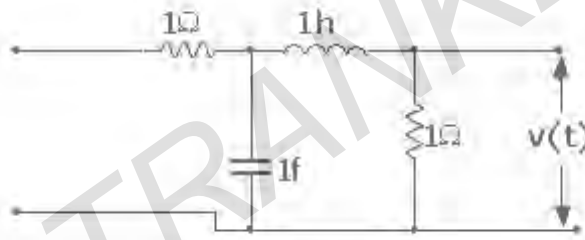

Figure 7b

- Find the Z transform of $t^2 e^{-at}$.
 - Find the final value and initial value of $x(n)$ for $X(z) = \frac{z^2}{(z-1)(z-0.2)}$. [8+8]
- Explain the Graphical Evaluation of a component of one function in other function.
 - Sketch the single sided and double sided spectra of the following signal:
 $x(t) = 4 \sin(10\pi t - \frac{\pi}{6})$. [10+6]
- Obtain the Trigonometric Fourier series for the function $f(t)$ as shown in figure 6a

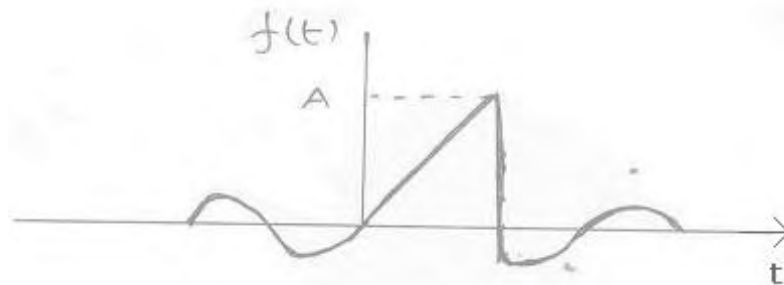

Figure 6a

- Use the definition of the Fourier series to determine the time domain representation signals represented by the following Fourier series coefficients.

Code No: 07A3EC12

R07

Set No. 1

- i. $C_n = j\delta(n+1) - j\delta(n-1) + j\delta(n-3) + j\delta(n+1)$ and $\omega_0 = 4\pi$
 ii. $C_n = \left(-\frac{1}{5}\right)^{|n|}$, $\omega_0 = 1$. [8+8]

5. (a) Find the Fourier Transform for the following functions shown in figure 1a.

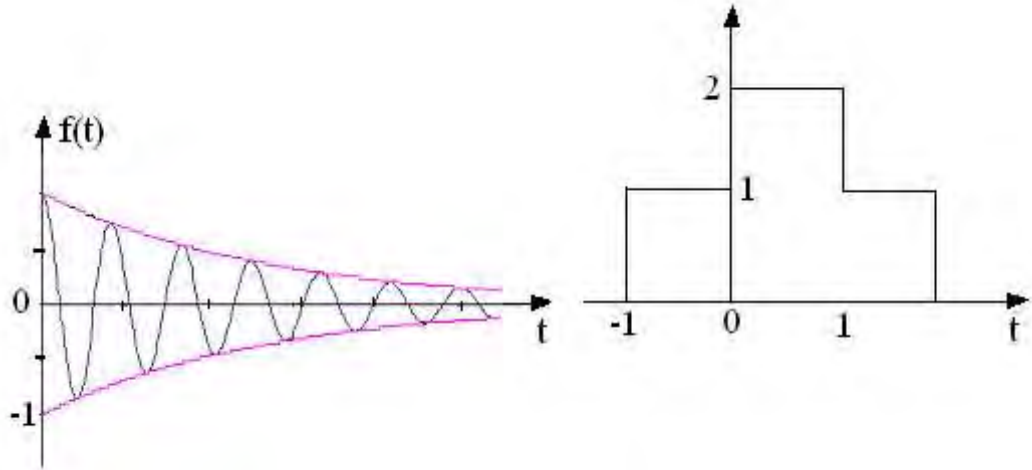

Figure 1a

- (b) Find the total area under the function $g(t) = 100 \sin c((t-8)/30)$. [10+6]
6. (a) State and Prove Properties of cross correlation function.
 (b) If $v(f) = AT \frac{\sin 2\pi f T}{2\pi f T}$ find the energy contained in $V(t)$. [8+8]
7. (a) Determine the Nyquist rate corresponding to each of the following signals.
 i. $x(t) = 1 + \cos 2000 \pi t + \sin 4000 \pi t$
 ii. $x(t) = (\sin 4000 \pi t) / \pi t$
 (b) The signal, $Y(t)$ is generated by convolving a band limited signal $X_1(t)$ with another band limited signal $X_2(t)$ that is
 $Y(t) = X_1(t) * X_2(t)$
 Where,
 $X_1(j\omega) = 0$ for $|\omega| > 1000\pi$
 $X_2(j\omega) = 0$ for $|\omega| > 2000\pi$
 Impulse train sampling is performed on $y(t)$ to obtain
 $y_p(t) = \sum_{n=-\infty}^{\infty} y(nT) \delta(t - nT)$
 Specify the range of values for sampling period T which ensures that $y(t)$ is recoverable from $Y_p(t)$. [8+8]
8. (a) When is a function $f(t)$ is said to be laplace transformable.
 (b) What do you mean by region of convergence?
 (c) List the advantages of Laplace transform.
 (d) If $\delta(t)$ is a unit impulse function find the laplace transform of $d^2/dt^2 [\delta(t)]$. [4+4+4+4]

Code No: 07A3EC12

R07

Set No. 3

II B.Tech I Semester Examinations, MAY 2011
SIGNALS AND SYSTEMS
Common to BME, ETM, E.CONT.E, EIE, ECE

Time: 3 hours

Max Marks: 80

Answer any FIVE Questions
All Questions carry equal marks

1. (a) Find the Fourier Transform for the following functions shown in figure 1a.

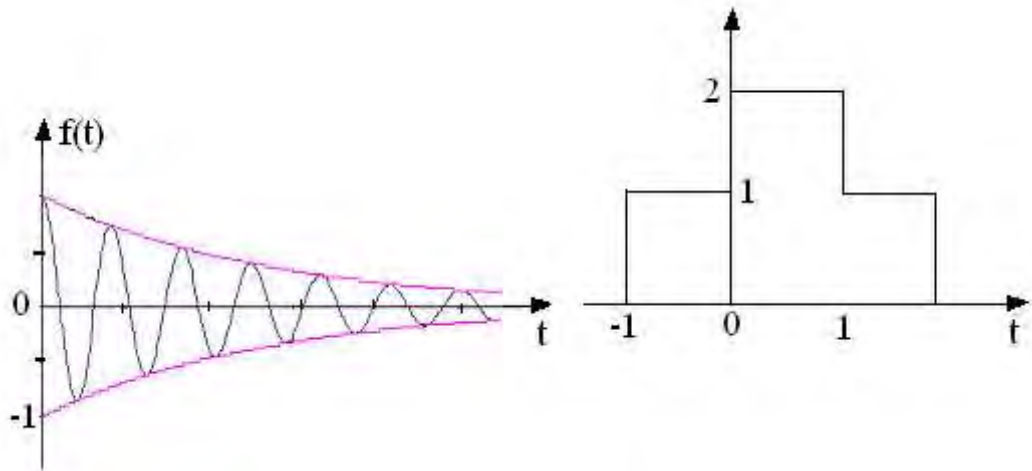

Figure 1a

- (b) Find the total area under the function $g(t) = 100 \sin c((t-8)/30)$. [10+6]
2. (a) When is a function $f(t)$ is said to be laplace transformable.
 (b) What do you mean by region of convergence?
 (c) List the advantages of Laplace transform.
 (d) If $\delta(t)$ is a unit impulse function find the laplace transform of $d^2/dt^2 [\delta(t)]$. [4+4+4+4]
3. (a) Determine the Nyquist rate corresponding to each of the following signals.
 i. $x(t) = 1 + \cos 2000 \pi t + \sin 4000 \pi t$
 ii. $x(t) = (\sin 4000 \pi t) / \pi t$
- (b) The signal, $Y(t)$ is generated by convolving a band limited signal $X_1(t)$ with another band limited signal $X_2(t)$ that is
 $Y(t) = X_1(t) * X_2(t)$
 Where,
 $X_1(j\omega) = 0$ for $|\omega| > 1000\pi$
 $X_2(j\omega) = 0$ for $|\omega| > 2000\pi$
 Impulse train sampling is performed on $y(t)$ to obtain
 $y_p(t) = \sum_{n=-\infty}^{\infty} y(nT) \delta(t - nT)$
 Specify the range of values for sampling period T which ensures that $y(t)$ is recoverable from $Y_p(t)$. [8+8]

Code No: 07A3EC12

R07**Set No. 3**

4. (a) Find the Z transform of $t^2 e^{-at}$.
 (b) Find the final value and initial value of $x(n)$ for $X(z) = \frac{z^2}{(z-1)(z-0.2)}$. [8+8]
5. (a) Explain the Graphical Evaluation of a component of one function in other function.
 (b) Sketch the single sided and double sided spectra of the following signal:
 $x(t) = 4 \sin(10\pi t - \frac{\pi}{6})$. [10+6]
6. (a) Obtain the Trigonometric Fourier series for the function $f(t)$ as shown in figure 6a

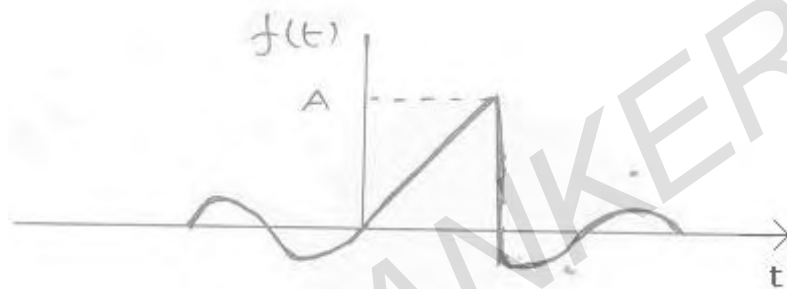

Figure 6a

- (b) Use the definition of the Fourier series to determine the time domain representation signals represented by the following Fourier series coefficients.
- $C_n = j\delta(n+1) - j\delta(n-1) + j\delta(n-3) + j\delta(n+1)$ and $\omega_0 = 4\pi$
 - $C_n = (-\frac{1}{5})^{|n|}$, $\omega_0 = 1$. [8+8]
7. (a) The transfer function of an ideal low pass filter is given by $H(j\omega) = K G_w(\omega) e^{-j\omega t_0}$
 Evaluate the unit step response of this filter.
 (b) Find the output voltage $V(t)$ of a network shown in figure 7b. when the voltage applied to the terminals ab is given by $t e^{-t} u(t)$

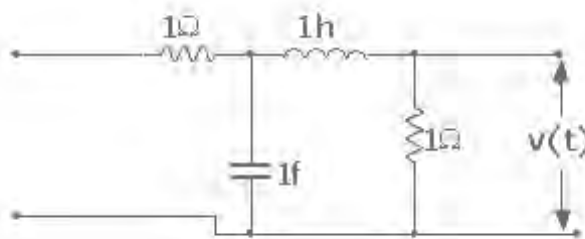

Figure 7b

8. (a) State and Prove Properties of cross correlation function.
 (b) If $v(f) = AT \frac{\sin 2\pi fT}{2\pi fT}$ find the energy contained in $V(t)$. [8+8]
