

Code No: 07A5EC03

R07**Set No. 2**

III B.Tech I Semester Examinations, May 2011

DYNAMICS OF MACHINERY

Common to Mechanical Engineering, Production Engineering, Automobile Engineering

Time: 3 hours

Max Marks: 80

Answer any FIVE Questions
All Questions carry equal marks

1. (a) Derive a relation for the turning moment at the crankshaft in terms of the piston effort and the angle turned by the crank.
- (b) Draw the tuning moment diagrams for the following different types of engines, neglecting the effect of inertia of the connecting rod :
 - i. Single cylinder double acting steam engine
 - ii. Four stroke cycle. I.C. engine [8+8]
2. (a) Explain clearly how would you determine from the controlling force curve whether the governor is stable, unstable, isochronous. Show also how the effect of friction may be indicated on the curve.
- (b) Prove that the sensitiveness of a Proell governor is greater than that of a Porter governor. [8+8]
3. The revolving masses for a single crank engine are equivalent to a mass of 100 kg at a radius of 225 mm. Determine the position and magnitude of the balance mass at a radius of 600 mm in two planes 1 and 2 at a distance of 300 mm and 900 mm from the plane of the crank, when
 - (a) these planes are on the opposite sides of the crank
 - (b) these are both on the same side of the crank. [16]
4. (a) What are the differences between reverse and direct crank methods of balancing of reciprocating engines
- (b) A single cylinder horizontal engine runs at 120 r.p.m. The length of stroke is 400 mm. The mass of the revolving parts assumed concentrated at the crank pin is 100kg and mass of the reciprocating parts is 150kg. Determine the magnitude of the balancing mass required to be placed opposite to the crank at a radius of 150mm which is equivalent to all the revolving and $\frac{2}{3}$ rd of the reciprocating mass. If the crank turns 30° from the inner dead centre, find the magnitude of the unbalanced force due to the balancing mass. [6+10]
5. (a) What are the conditions for a body to be in equilibrium under the action of two forces, three forces and two forces and a torque?
- (b) Determine the required input torque on the crank of a slider-crank mechanism for the static equilibrium when the applied piston load is 1500N . The lengths of the crank and the connecting rod are 40 mm and 100 mm respectively, and the crank has turned through 45° from the inner-dead centre. [8+8]

Code No: 07A5EC03

R07

Set No. 2

6. (a) How the natural frequency of torsional vibrations for a two rotor system is obtained?
- (b) A 15 kg mass is mounted on springs and is fitted with a dashpot to damp out vibrations. There are three springs each of stiffness 16 N/mm and it is found that the amplitude of vibration diminished from 40 mm to 7 mm in two complete oscillations. Assuming that the damping force varies as the velocity, determine
- the resistance of the dash pot at unit velocity
 - the ratio of the frequency of the damped vibration to the frequency of the undamped vibration
 - the periodic time of the damped vibration. [6+10]
7. (a) What do you understand by 'self-locking brake' and 'self-energized brake'? Should we have self-locking brake or self-energized brake? Justify your answer.
- (b) In the differential band brake, as shown in Figure 1 the diameter of the drum is 900 mm, and the coefficient of friction between the drum and the band is 0.3. The angle of contact is 240° . When a force of 650 N is applied at the free end of the lever, find the maximum and the minimum force in the band, and the torque which can be applied by the brake.

[6+10]

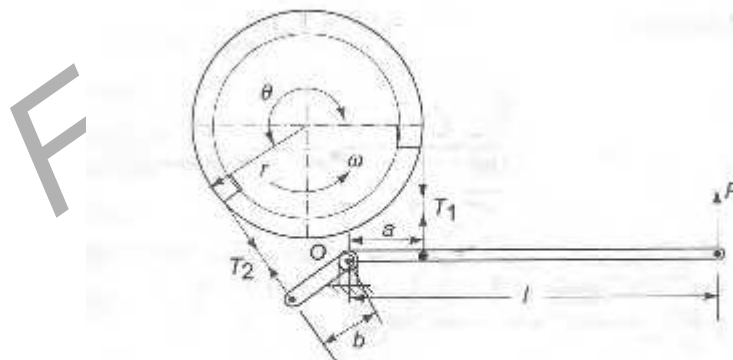

Figure 1:

8. The thrust on the propeller shaft of a marine engine is taken by 8 collars whose external and internal diameters are 650 mm and 400 mm respectively. The thrust pressure is 0.5 MPa and may be assumed uniform. The coefficient of friction between the shaft and collars is 0.04. If the shaft rotates at 120 rpm, find (a) the total thrust on the collars, and (b) the power absorbed by friction at the bearing. [16]

Code No: 07A5EC03

R07

Set No. 2

FIRSTRANKER

Code No: 07A5EC03

R07**Set No. 4**

III B.Tech I Semester Examinations, May 2011

DYNAMICS OF MACHINERY

Common to Mechanical Engineering, Production Engineering, Automobile Engineering

Time: 3 hours

Max Marks: 80

Answer any FIVE Questions
All Questions carry equal marks

1. (a) Find an expression for the braking torque for a single shoe brake when the brake drum is rotating clockwise, and the friction force is at a distance 'b' below the fulcrum.
(b) In a double shoe brake, the diameter of the brake drum is 350 mm, and the contact angle for each shoe is 120° . The coefficient of friction for the brake lining and drum is 0.35. Find the necessary spring force to transmit a torque of 40 N-m. The distance of the centre of brake drum from the fulcrum and from the spring is 250 mm and 300 mm respectively. [8+8]
2. (a) Prove the relation that hammer blow is $\pm m_b r \omega^2$.
(b) A four cylinder inline marine oil engine has cranks at angular displacement of 90° . The outer cranks are 3m apart and inner cranks are 1.2 m apart. The inner cranks are placed symmetrically between the outer cranks. The length of each crank is 450mm. If the engine runs at 90r.p.m. and the mass of reciprocating parts for each cylinder is 900 kg. Find the firing order of the cylinders for the best primary balancing force of reciprocating masses. Determine the maximum unbalanced primary couple for the best arrangement. [6+10]
3. (a) What do you mean by gyroscopic couple? Derive a relation for its magnitude.
(b) What do you mean by spin, precession and gyroscopic planes? Explain. [8+8]
4. (a) Explain the terms Balancing of Rotating masses. What will be the harm if the rotating parts of a high speed engine are not properly balanced?
(b) Three masses P, Q and R with masses 12 kg, 11 kg and 18 kg respectively revolve in the same plane at radii 120 mm, 144 mm and 70 mm respectively. The angular position of Q and R are 60° and 135° from P. Determine the position and magnitude of mass S at radius 152 mm to balance the system. [6+10]
5. (a) Discuss the effect of inertia of a shaft on free torsional vibrations.
(b) A shaft of 100 mm diameter and 1 m long is fixed at one end and the other end carries a fly wheel of mass 1000 kg. The radius of gyration of the flywheel is 0.4 m. Find the frequency of torsional vibrations if the modulus of rigidity for the shaft material is 80 GN/m². [6+10]

Code No: 07A5EC03

R07

Set No. 4

6. A horizontal steam engine running at 180 rpm has a bore of 320 mm and stroke 560 mm. The connecting rod is 1 m long, and the mass of the reciprocating parts is 50 kg. When the crank is 50° past the inner dead centre, the steam pressure on the cover side of the piston is 1.2 MPa, while that on the crank side is 0.15 MPa. Neglecting the area of the piston rod, determine (a) the force on the piston, and (b) the turning moment on the crankshaft. [16]
7. (a) The movable jaw of a bench vice is at the upper end of a hinged arm 0.5 m long, the centre line of the screw being 400 mm above the hinge. The screw is of 25 mm outside diameter, and has 6 mm pitch. The mean radius of the thrust collar is 30 mm. Find the tangential force to be applied to the screw at a radius of 300 mm to produce a force of 6 kN at the jaw. Also find the mechanical efficiency of the vice.
- (b) Derive an expression for the least force required to drag a body on a rough horizontal plane [10+6]
8. (a) Define the terms controlling force and effort of a governor mechanism.
- (b) In a spring-loaded Hartnell type of governor, the mass of each ball is 4 kg and the lift of the sleeve is 30 mm. The governor begins to float at 400 rpm when the radius of the ball path is 80 mm. The mean working speed of the governor is 14 times the range of speed when friction is neglected. The lengths of the ball and roller arms of the bell-crank lever are 120 mm and 75 mm respectively. The pivot centre and the axis of governor are 125 mm apart. Determine the initial compression of the spring, taking into account the obliquity of arms. Assuming the friction at the sleeve to be equivalent to a force of 25 N, determine the total alteration in speed before the sleeve begins to move from the mid-position. [6+10]

Code No: 07A5EC03

R07**Set No. 1**

III B.Tech I Semester Examinations, May 2011

DYNAMICS OF MACHINERY

Common to Mechanical Engineering, Production Engineering, Automobile Engineering

Time: 3 hours

Max Marks: 80

Answer any FIVE Questions
All Questions carry equal marks

1. (a) Find an expression for the braking torque for a single shoe brake when the brake drum is rotating anti-clock wise, and the friction force is at a distance 'b' above the fulcrum.
- (b) A torsion dynamometer is fitted on a turbine shaft to measure the angle of twist. It is observed that the shaft twists 2° in a length of 5 m at 600 rpm. The shaft is solid and has a diameter of 250 mm. If the modulus of rigidity is 84 GPa, find the power transmitted by the turbine. [8+8]
2. (a) Distinguish the static balance and dynamic balance with appropriate examples
- (b) A mass is attached to a shaft which is rotating at an angular speed of ω rad /s. Describe the procedure of balancing this mass by
 - i. a single mass only
 - ii. two masses in different planes. [8+8]
3. (a) Explain the terms
 - i. Primary disturbing force and
 - ii. secondary disturbing force.
- (b) The two cylinder engine with crank set 180° and the cylinders on the same side of the crank shaft centre line is having identical reciprocating masses, crank lengths and connecting rod lengths for each cylinder. If the crank of the first cylinder makes an angle of 30° with IDC then to what extent the engine is balanced for
 - i. Primary and secondary forces
 - ii. Primary and secondary couples. [6+10]
4. (a) Explain what is meant by vibration isolation with neat sketches?
- (b) A shaft of 100 mm diameter and 1 m long is fixed at one end and other end carries a fly wheel of mass 1 tonne taking Youngs modulus for the shaft material as 200 GN/m^2 , find the natural frequency of longitudinal and transverse vibrations. [6+10]
5. (a) Deduce an expression for the couple that is called into play in the case of a wheel rotating with uniform angular velocity in order to maintain a given rate of precession.

Code No: 07A5EC03

R07

Set No. 1

(b) An aeroplane makes a complete half circle of 60 m radius towards left when flying at 250 km/h. The rotary engine and the propeller of the plane has a mass of 450 kg with a radius of gyration of 300 mm. The engine runs at 2400 rpm clockwise when viewed from the rear. Find the gyroscopic effect on the aircraft. [8+8]

6. (a) An engine has 3 single acting cylinders whose cranks are spaced at 120° to each other. The turning moment diagram for each cylinder consists of a triangle having the following values.

Angle	0°	60°	180°	180°-360°
Torque (N-m)	0	200	0	0

Find the mean torque and the moment of the inertia of the flywheel to keep the speed with in 180 ± 3 rpm.

(b) Draw the turning moment diagram for a single cylinder double-acting steam engine. [10+6]

7. (a) Describe the effect of friction on the sensitiveness of a governor.

(b) In a spring loaded Hartnell type of governor, the mass of each ball is 12 kg and the lift of the sleeve is 65 mm. The governor begins to float at 275 rpm, when radius of the ball path is 150 mm. The mean working speed of the governor is 24 times the range of the speed when friction is neglected. The lengths of the ball and roller arms of the bell-crank lever are 140 mm and 120 mm respectively. The pivot centre and the axis of the governor are 160 mm apart. Determine the initial compression of the spring, taking in to consideration of arms. [6+10]

8. The spindle of a screw jack has single start square threads with an outside diameter of 45 mm and a pitch of 10 mm. The spindle moves in a fixed nut. The load is carried on a swivel head, but is not free to rotate. The bearing surface of the swivel head has a mean diameter of 60 mm. The coefficient of friction between the nut and screw is 0.12, and that between the swivel head and the spindle is 0.10. Calculate the load which can be raised by efforts of 100 N each, applied at the end of two levers, each of effective length 350 mm. Also determine the velocity ratio and the efficiency of the lifting arrangement. [16]

Code No: 07A5EC03

R07**Set No. 3**

III B.Tech I Semester Examinations, May 2011

DYNAMICS OF MACHINERY

Common to Mechanical Engineering, Production Engineering, Automobile Engineering

Time: 3 hours

Max Marks: 80

Answer any FIVE Questions
All Questions carry equal marks

1. (a) Which of the two assumptions, uniform intensity of pressure or uniform rate of wear, would you make use of in designing a friction clutch and why?
(b) What are the different types of friction clutches? Describe with a neat sketch the working of a cone clutch. [8+8]
2. (a) Prove that maximum secondary unbalanced forces is $1/n$ times maximum primary unbalanced for n cylinder reciprocating engine.
(b) Prove that the limiting conditions for the angular speed when the wheel does not lift from the rails is given by, $\omega = \sqrt{(P/m_b xr)}$
Where P = static wheel load, m_b = Balancing mass placed at a radius of r . [8+8]
3. (a) Explain the gyroscopic effect on four wheeled vehicles.
(b) The rotor of the turbine of a ship makes 1500 rpm clockwise when viewed from the stern. The rotor has a mass of 800 kg and its radius of gyration is 300 mm. Find the maximum gyro-couple transmitted to the hull when the ship pitches with maximum angular velocity of 1 rad/s. [8+8]
4. (a) Explain precisely the role played by reference plane in balancing masses rotating in different planes.
(b) A shaft of length 2.5 m between centres carrying two weights on it runs at 150 rpm. The distance of 20 kg weight and of 30 kg weight both from left hand bearing are 1200 mm and 2000 mm. The radius of rotation of 20 kg weight is 500 mm and that of 30 kg weight is 800 mm. The angle between the weights is 60° . Find the magnitude and the position of balancing masses at 600 mm radius and at 300 mm distance from each bearing. Neglect the effect weight of shaft. [6+10]
5. A truncated conical pivot of cone angle ϕ and rotating at a speed N supports a load W . The smallest and the largest diameters of the pivot over the contact area are 'd' and 'D' respectively. Assuming uniform wear, derive the expression for the frictional torque, and hence determine the power lost in overcoming friction, if $W=20$ kN, $d = 100$ mm, $D = 300$ mm, $\phi = 120^\circ$, $N = 150$ rpm and the coefficient of friction $\mu = 0.06$. (Here ϕ means 2α) [16]
6. (a) Prove that the Coefficient of fluctuation of speed (K_s) is given by:
$$K_s = 2 (\omega_1 - \omega_2) / (\omega_1 + \omega_2)$$

Code No: 07A5EC03

R07**Set No. 3**

where ω_1 = max. angular velocity of flywheel, and
 ω_2 = min. angular velocity of flywheel.

- (b) The effective steam pressure on the piston of a vertical steam engine is 200 kN/m^2 when the crank is 40° from the inner dead centre on the down stroke. The crank length is 300 mm, and the connecting length is 1200 mm. Diameter of the cylinder is 800 mm. What will be the torque on the crankshaft if the engine speed is 300 rpm, and the mass of the reciprocating parts is 250 kg? [8+8]
7. (a) An unknown spring constant K has a natural frequency of 100 cycles per minute. When 1.2 kg mass is added to m , the natural frequency is lowered to 80 cycles per minute, determine the unknown mass m and the spring constant K in N/mm.
- (b) A vertical shaft 40 mm diameter and 1.3 m long is mounted in long bearings and carries a pulley of mass 50 kg midway between the bearings. The centre of pulley is 0.8 m from the axis of the shaft. Find
- the whirling and
 - the bending stress in the shaft, when it is rotating at 2000 rpm. Take Young's modulus of the material of the shaft as 200 GN/m^2 . [8+8]
8. (a) What is power of a governor and how is it determined?
- (b) The total sleeve movement in a spring-controlled Hartnell governor is 25 mm. The mass of the rotating balls is 1.25 kg each. At the mid position of the sleeve, the sleeve arm, which is 64 mm long, is horizontal. The ball arm has a length of 80 mm. At the mid position of the sleeve, the balls rotate at a radius of 130 mm. Due to the adjustment of the spring, the equilibrium governor speed at the top most position of the sleeve is 460 rpm and that corresponding to the lowest position of the sleeve is 425 rpm. Determine
- the stiffness and initial compression of the spring, and
 - the required initial compression of the spring to give an equilibrium speed at the topmost position which is 17 rpm more than that at the lowest position. Neglect the moment due to the weight of the ball. [6+10]
