

Code No: 07A5EC16

R07**Set No. 2**

III B.Tech I Semester Examinations, May 2011

CONTROL SYSTEMSCommon to Aeronautical Engineering, Electronics And Instrumentation
Engineering

Time: 3 hours

Max Marks: 80

Answer any FIVE Questions
All Questions carry equal marks

1. (a) Show that in Bode magnitude plot, the slope corresponding to a quadratic factor is -40 dB/dec.
- (b) Draw the Bode Plot for the system having $G(s)H(s) = \frac{100(0.02s+1)}{(s+1)(0.1s)(0.01s+1)}$. Find gain margin and phase crossover frequency.
- (c) Explain with the help of examples:
 - i. Minimum phase function
 - ii. Non minimum phase function
 - iii. All pass function. [4+6+6]
2. (a) Explain the effect of damping ratio on a second order system by taking different values of damping ratio.
- (b) Define time response specifications. [8+8]
3. Write short notes on:
 - (a) Comparison of polar & Nyquist plots
 - (b) Applications of Nyquist criterion. [8+8]
4. (a) Investigate the stability of a control system whose characteristic equation is given by:

$$s^4 + 3s^3 + 5s^2 + 2s + 10 = 0$$
- (b) Explain the steps followed for construction of Root locus by taking an example. [8+8]
5. (a) What is PI - controller and what are the effects of it on system performance?
- (b) Consider a unity feedback system with open loop transfer function, $G(s) = \frac{100}{(s+1)(s+2)(s+5)}$. Design a PI - controller, so that the phase margin of the system is 60° at a frequency of 0.5 rad/sec. [6+10]
6. (a) Obtain the transfer function of the following system shown in figure 1 and draw its analogous electrical circuit.
- (b) Explain the advantages and features of transfer function. [8+8]

Code No: 07A5EC16

R07

Set No. 2

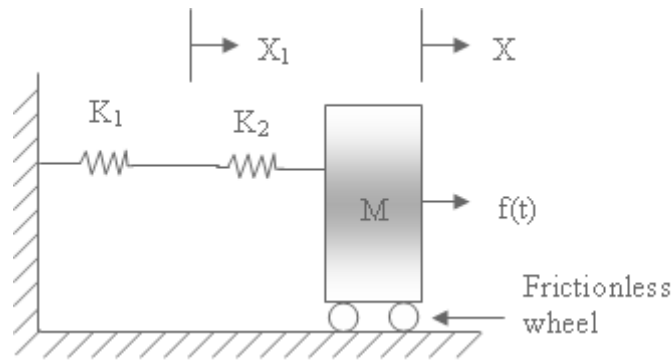

Figure 1

7. (a) Obtain the solution of a system whose state model is given by $\dot{X} = A X(t) + B U(t)$; $X(0) = X_0$ and hence define State Transition Matrix.

- (b) Obtain the transfer function of a control system whose state model is

$$\dot{x}(t) = A x(t) + B u(t)$$

$$y(t) = C x(t)$$

$$\text{where } A = \begin{bmatrix} 0 & 1 & 0 \\ 0 & -1 & 1 \\ 0 & -1 & -10 \end{bmatrix} \quad B = \begin{bmatrix} 0 \\ 0 \\ 10 \end{bmatrix} \quad C = [1 \ 0 \ 0] .$$

[8+8]

8. (a) Determine the Transfer Functions $\frac{C_1}{R_1}$, $\frac{C_2}{R_2}$ and $\frac{C_2}{R_1}$ for the following block diagram shown in figure 2.

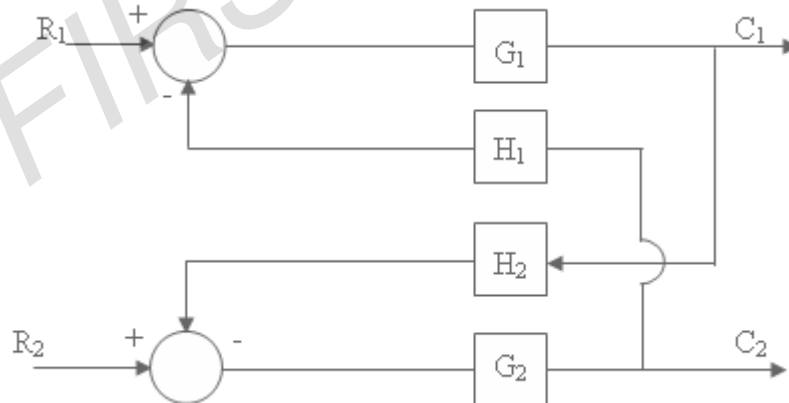

Figure 2:

- (b) Mention the merits and demerits of an open-loop and closed-loop control systems. Give real time applications of an closed loop system. [8+8]

Code No: 07A5EC16

R07

Set No. 4

III B.Tech I Semester Examinations, May 2011
CONTROL SYSTEMS

Common to Aeronautical Engineering, Electronics And Instrumentation
Engineering

Time: 3 hours

Max Marks: 80

Answer any FIVE Questions
All Questions carry equal marks

1. (a) With reference to feedback control system shown in figure 3 define the following terms:
 - i. Command input
 - ii. Reference input
 - iii. Forward path
 - iv. Feedback path.
- (b) Derive the transfer function for the Parallel RLC network. [8+8]

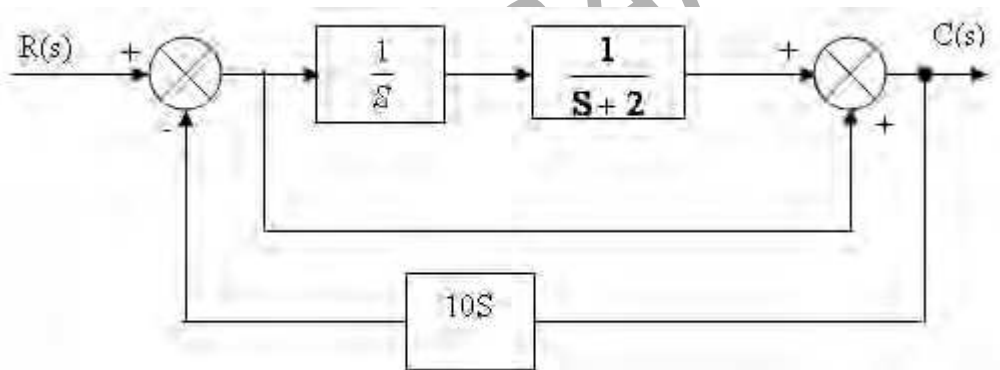

Figure 3:

2. (a) The system is represented by the differential equation $\ddot{y} + 5\dot{y} + 6y = u$. Find the transfer function from state variable representation.
- (b) Consider the RLC network is shown in figure 4. Write the state variable representation. [8+8]
3. (a) Derive the expressions for resonant peak & resonant frequency and hence establish the correlation between time response & frequency response.
- (b) Given $\zeta = 0.7$ & $\omega_n = 10$ rad/s find resonant peak, resonant frequency & Bandwidth. [10+6]
4. (a) Explain the procedure for deriving the transfer function and derive the transfer function for servo.
- (b) Reduce the block diagram shown in figure 5 using block diagram reduction technique and compute $C(s)/R(s)$. [8+8]

Code No: 07A5EC16

R07

Set No. 4

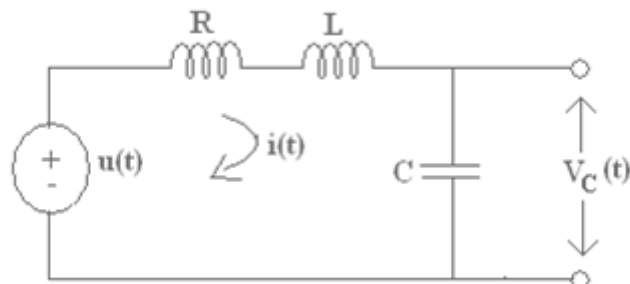

Figure 4:

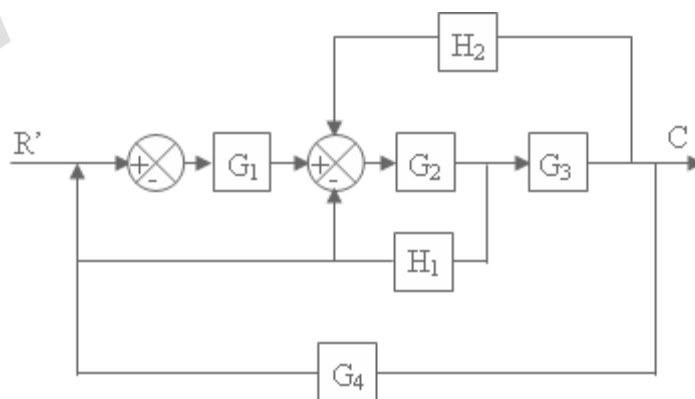

Figure 5:

Code No: 07A5EC16

R07

Set No. 4

5. Draw the Nyquist Plot for the open loop system $G(s) = \frac{K(s+3)}{s(s-1)}$ and find its stability. Also find the phase margin and gain margin. [16]
6. The open loop transfer function of unity feedback is $G(s) = \frac{1}{s(s+1)(0.5s+1)}$. Design a compensator to meet the following specifications: Velocity error constant $K_v = 5 \text{ sec}^{-1}$; phase margin = 40° ; Gain margin = 10 db. [16]
7. The system shown in Figure 6 is a unity feedback control system with minor feedback loop (output derivative feedback).

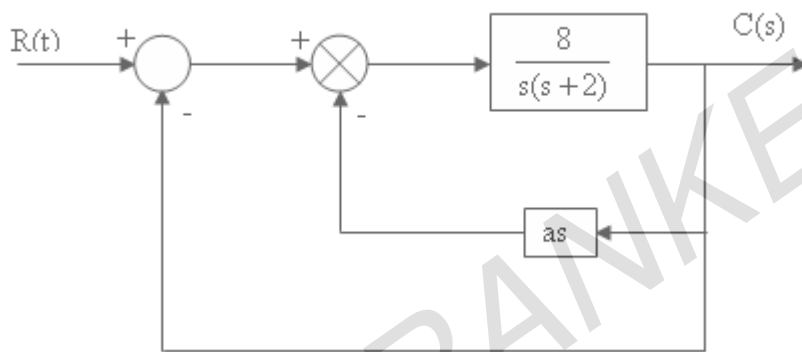

Figure 6:

- (a) In the absence of derivative feedback ($a=0$), determine the damping ratio and natural frequency. Also determine the steady state error resulting from the unit ramp input. [16]
- (b) Determine the derivative feedback constant 'a' which will increase the damping factor of the system to 0.7. What is the steady state error to unit ramp input with this setting of the derivative feedback constant?
- (c) Illustrate how the steady state error of the system with derivative feedback to unit ramp input can be reduced to the same value as in part (i), while the damping factor is maintained at 0.7. [16]
8. (a) Briefly discuss the merits and demerits of R-H stability criterion. Determine the value of K such that the system is stable for the open-loop transfer function of a control system which is given by $G(s)H(s) = \frac{K}{s(s+2)(s+4)}$
- (b) A unity feedback system has an open-loop transfer function $G(s) = \frac{K}{s(1+0.02s)(1+0.01s)}$. Sketch the root-locus of the system. [8+8]

Code No: 07A5EC16

R07**Set No. 1**

**III B.Tech I Semester Examinations, May 2011
CONTROL SYSTEMS**

**Common to Aeronautical Engineering, Electronics And Instrumentation
Engineering**

Time: 3 hours

Max Marks: 80

**Answer any FIVE Questions
All Questions carry equal marks**

- Explain various types of compensations.
 - Obtain the transfer function of lag compensator. [8+8]
- Explain the working of an Amplidyne and derive its transfer function.
 - Derive the transfer functions of AC servomotor and A.C. tachometer. [8+8]
- Explain how the type of a system determines the shape of polar plot.
 - Write a note on Nyquist criterion for minimum phase & non minimum phase transfer functions. [8+8]
- Sketch the root locus of the unity feedback control system
 $G(s) = \frac{K(s+3)}{(s(s+6)(s^2+2s+2))}$

 - Find the marginal value of 'K'.
 - Find the value of 'K' for damping ratio of 0.5.
 - Determine the expression for M_P , ω_n , and bandwidth for a second order system. [16]
- Explain the concept of physical system and physical model.
 - For the mechanical system shown in figure 7 derive an expression for the transfer function $\frac{X_2(s)}{F(s)}$. [8+8]

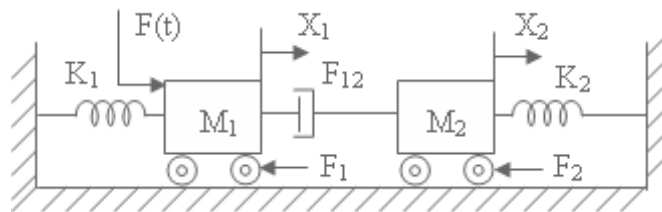

Figure 7:

- Explain the concept of phase margin and gain margin.
 - Draw the Bode Plot for a system having $G(s) = \frac{100}{s(1+0.5s)(1+0.1s)}$, $H(s) = 1$. Determine:
 - Gain crossover frequency and corresponding phase margin.

Code No: 07A5EC16

R07**Set No. 1**

- ii. Phase crossover frequency and corresponding gain margin.
- iii. Stability of the closed loop system. [8+8]

7. A system has the state variable model:

$$\dot{x} = \begin{bmatrix} 0 & 1 \\ -a & -b \end{bmatrix} \begin{bmatrix} x_1 \\ x_2 \end{bmatrix} + \begin{bmatrix} 0 \\ c \end{bmatrix} u$$

$$y = \begin{bmatrix} 10 & 0 \end{bmatrix} x$$

It is desired that the canonical form be

$$\dot{z} = \begin{bmatrix} -3 & 0 \\ 0 & -1 \end{bmatrix} z + \begin{bmatrix} 1 \\ 1 \end{bmatrix} u$$

$$y = \begin{bmatrix} -5 & 5 \end{bmatrix} z$$

Determine the parameters a,b,c. Obtain the step response of the system assuming

$$x(0) = \begin{bmatrix} 1 \\ -1 \end{bmatrix} \quad [16]$$

8. (a) Derive the time response specifications for unit step response for a second order system for underdamped case.
- (b) With a neat sketch, explain about PD type of controller. [8+8]

Code No: 07A5EC16

R07**Set No. 3**

III B.Tech I Semester Examinations, May 2011
CONTROL SYSTEMS

Common to Aeronautical Engineering, Electronics And Instrumentation
Engineering

Time: 3 hours

Max Marks: 80

Answer any FIVE Questions
All Questions carry equal marks

1. (a) What way feedback control systems are superior to open loop systems?
- (b) For the mechanical system shown in figure 8, determine the transfer function $\frac{Y_1(s)}{F(s)}$ and $\frac{Y_2(s)}{F(s)}$. [16]

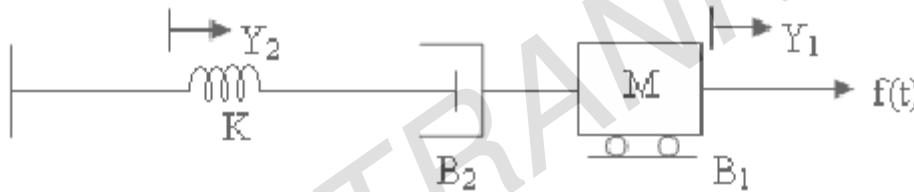

Figure 8:

2. (a) Explain the term frequency response analysis.
- (b) Sketch the Bode Plot for the Transfer function $G(s) = \frac{Ke^{-0.5s}}{s(2+s)(1+0.3s)}$ and determine the system gain 'K' for the gain crossover frequency ω_0 to be 5 rad/sec. [8+8]
3. With the help of examples, explain the effect of adding poles & zeros to the open loop transfer function $G(s)H(s)$ on the shape of Nyquist diagrams. [16]
4. (a) Obtain the state variable model in phase variable form for the following system: $\ddot{y} + 2\dot{y} + 3y = u(t)$.
- (b) The closed loop transfer function is given by $\frac{y(s)}{u(s)} = \frac{160(s+4)}{s^3+8s^2+192s+640}$. Obtain the state variable model using signal flow graph. [8+8]
5. (a) Derive the transfer function of an A.C. Servomotor and draw its characteristics.
- (b) A motor is connected to a load through a shaft having spring constant K. Write system equations for the figure 9. [8+8]

Code No: 07A5EC16

R07

Set No. 3

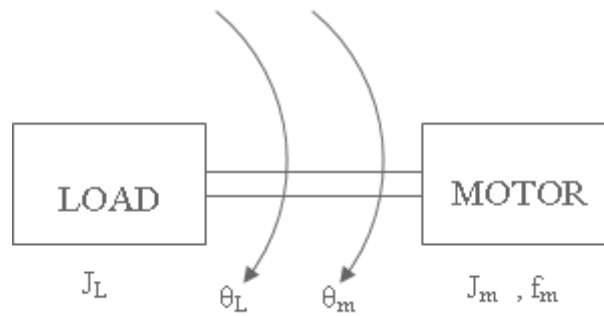

Figure 9

6. (a) For an under damped second order system, define various time domain specifications.
- (b) The forward path T.F. of a unity feed back control system is given by $G(s) = \frac{2}{s(s+3)}$. Obtain the expression for unit step response of the system. [8+8]
7. (a) Explain the RH stability Criterion?
- (b) A feed-back system has an open loop T.F of $G(s)H(s) = \frac{Ke^{-s}}{s(s^2+5s+9)}$. Determine by the use of the RH criterion, the max. value of K for the closed loop system to be stable. [8+8]
8. The controlled plant of a unity feedback system is $G(s) = \frac{K}{s(s+10)^2}$. It is specified that velocity error constant of the system be equal to 20, while the damping ratio of the dominant roots be 0.707. Design a suitable cascade compensation scheme to meet the specifications. [16]
