

Code No: 07A6EC05

R07**Set No. 2**

III B.Tech II Semester Examinations, APRIL 2011

DESIGN OF MACHINE MEMBERS-II

Common to Mechanical Engineering, Production Engineering

Time: 3 hours

Max Marks: 80

Answer any FIVE Questions

All Questions carry equal marks

1. (a) What are the basic requirements of a machine tools?
(b) Explain the design procedure for tailstock. [6+10]
2. A power screw having double start threads of 25mm nominal diameter and 5 mm pitch is acted upon by an axial load of 10kN. The outer and inner diameters of screw collar are 50 and 20mm respectively. The coefficient of thread friction and collar friction may be assumed as 0.2 and 0.15 respectively. The screw rotates at 12rpm. Assuming uniform wear condition at the collar and allowable thread bearing pressure of 5.8 N/mm² find:
 - (a) The torque required to rotate the screw.
 - (b) The stress in the screw and
 - (c) The number of threads of nut in engagement. [16]
3. (a) Draw the distribution of bending stresses in curved beams.
(b) Determine the stresses at section X-X of the punch as shown in figure 3b, W = 2 kN. [8+8]

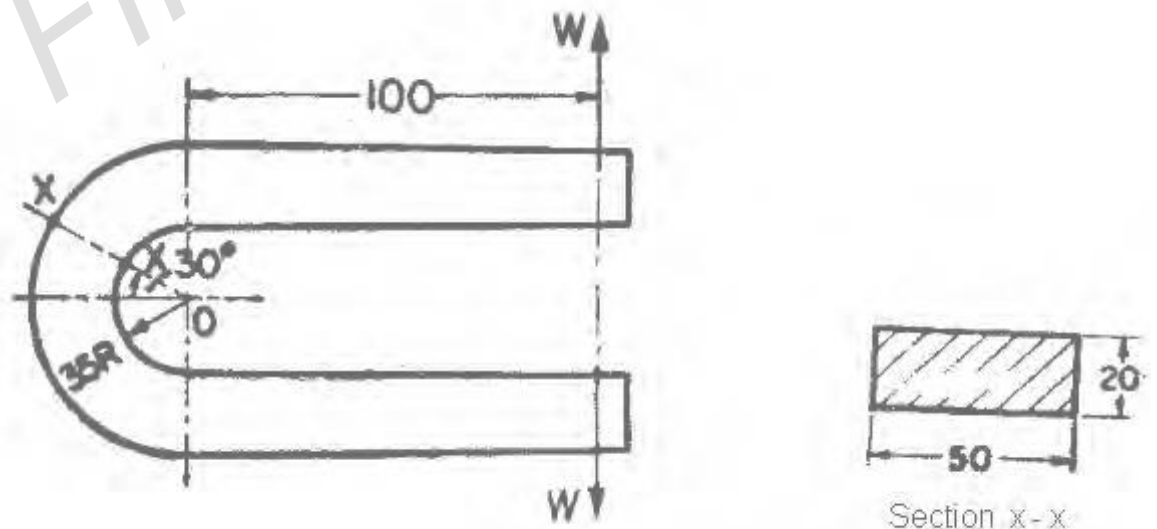

Figure 3b

4. (a) What are the causes of failure of gear tooth?
(b) Design a pair of spur gears with stub teeth to transmit 55kW from 175 mm pinion running at 2500 r.p.m. to a gear running at 1500 r.p.m. Both the gears

Code No: 07A6EC05

R07**Set No. 2**

are made of steel having B.H.N 260. Approximate the pitch by means of Lewis equation and then adjust the dimensions to keep within the limits set by the dynamic load and wear equation. [4+12]

5. Explain the following piston troubles and state under what conditions they will be experienced :

- (a) Burning of piston crown,
- (b) Seizure of piston,
- (c) Cracking of piston crown and side walls,
- (d) Breaking of piston rings,
- (e) Stocking of piston rings,
- (f) Excessive lubricating oil consumption,
- (g) Scuffing of piston rings and cylinder liners. [16]

6. (a) Compare ball and roller bearings
 (b) A rolling contact ball bearing is to be selected to support an overhung countershaft. The shaft speed is 720r.p.m. The bearing is to have 99% reliability corresponding to a life of 24000 hours. The bearing is subjected to an equivalent radial load of 1kN. Consider life adjustment factors for operating condition and material as 0.9 and 0.85 respectively. Find the basic dynamic load rating of the bearing from manufacturer's catalogue, specified at 90% reliability. [4+12]

7. Design a Connecting rod for a slow running four-cylinder engine. Rod is made of a material of ultimate strength 450Mpa and factor of safety of 9 is used for design. Following additional data are available:

Diameter of piston, = 98mm

Weight of reciprocating parts/cylinder = 1.82kg

Length of connecting rod = 300mm

Stroke = 140 mm

Speed = 2,000rpm

Compression ratio = 4

Maximum explosion pressure = 2.35Mpa

Density of material of connecting rod = 0.008kg/cm³

L/d ratio for big end bearing = 1.3

L/d ratio for small end bearing = 2.00

Use Rankine formula for finding the cross section of the rod, in which take $\sigma_c=315\text{Mpa}$ and factor of safety=5 for calculating buckling load. Allowable Stress in big end cap and bolt materials is 85 MPa and allowable pressure of 7MPa and 14MPa may be used for big end bearing and for wrist pin respectively. [16]

8. A CI flat pulley transmits 20kW at a speed of 560 rpm. The pulley overhangs the nearest bearing by 200mm. Assuming the ratio of the belt tension as 2, Determine

- (a) Shaft diameter

Code No: 07A6EC05

R07

Set No. 2

(b) Pulley diameter and Cross section of eight arms.

[16]

FIRSTRANKER

Code No: 07A6EC05

R07**Set No. 4**

III B.Tech II Semester Examinations, APRIL 2011

DESIGN OF MACHINE MEMBERS-II

Common to Mechanical Engineering, Production Engineering

Time: 3 hours

Max Marks: 80

Answer any FIVE Questions
All Questions carry equal marks

- Explain the following:
 - Design of drives
 - Force analysis of lathe guide ways. [8+8]
- The following particulars refer to a spur gear drive:
Centre distance = 300mm, Velocity ratio = 5, power = 70kW pinion speed = 1440 rpm, tooth profile = 20degree full depth involute, permissible normal load between the teeth = 1600N/mm of the face width
Design the drive. Also determine the load on the bearings, stating its nature. Assume that both the gears are mounted on overhanging shafts. [16]
- Design a piston, piston rings and gudgeon pin for a single four stroke engine for the following given data:
Cylinder bore = 100mm
Stroke = 125mm
Maximum gas pressure = 5MPa
b.m.e.p = 0.6MPa
Fuel consumption = 0.15kg/brake kW/hr
Speed = 1500rpm [16]
- Design and give a neat drawing of high speed petrol engine connecting rod, given:
Piston diameter = 100mm.
Stroke length = 138mm
Weight of reciprocating parts per cylinder = 1.8kg
Length of the connecting rod = 310mm
Rated rpm of the engine = 1500
Compression ratio = 4:1
Maximum explosion pressure = 2.45Mpa
Speed = 2500
Bearing pressure for big end = 7MPa
Bearing pressure for small end = 14MPa

Connecting rod should be of I-section and be made of forged steel, the proportions being depth $h=5t$, width $=4t$, where t is the flange and web thickness. [16]
- A curved beam has its centroidal line as a circular arc of 120 mm radius. The cross section of the beam is of T-shape with dimensions as shown in the figure

Code No: 07A6EC05

R07

Set No. 4

Determine the maximum tensile and compressive stresses set up by a bending moment of 6×10^4 N-mm tending to decrease the curvature. [16]

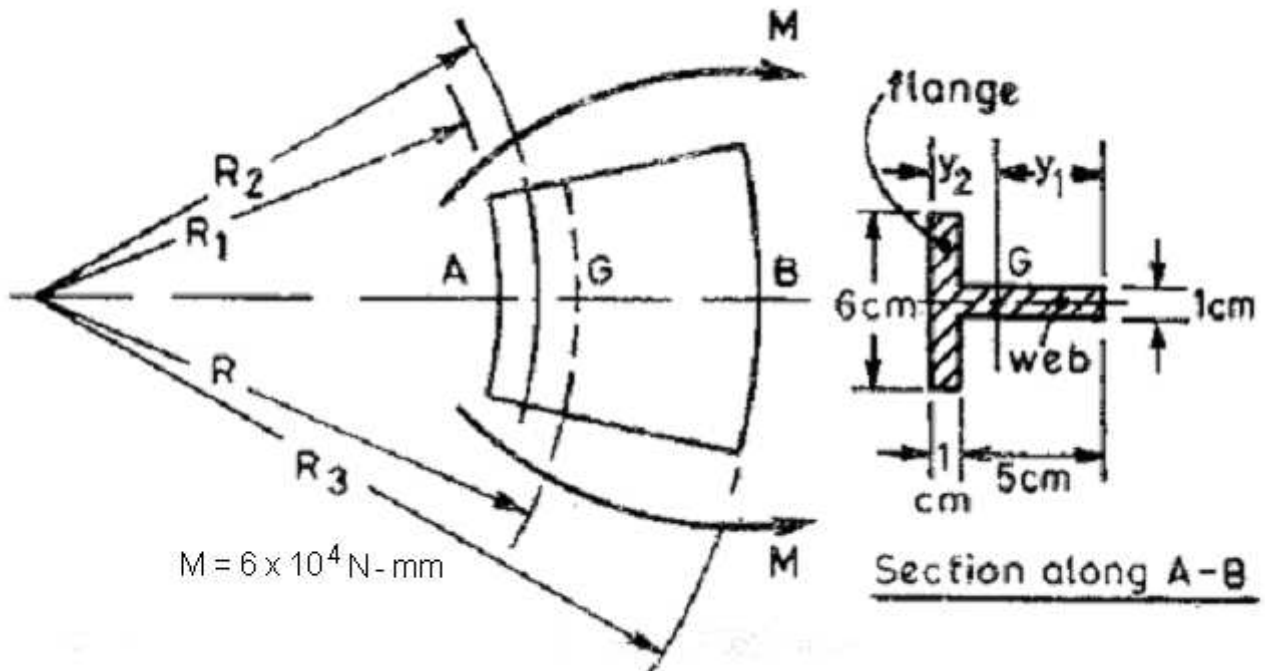

Figure 5

6.(a) How do you classify the chain drives.

(b) A rope drive is to transmit 250kW from a pulley of 1.2m diameter, running at a speed of 300 rpm. The angle of lap may be taken as π radians. The groove half angle is 22.5° . The ropes to be used are 50mm in diameter. The mass of the rope is 1.3 kg per meter length and each rope has a maximum pull of 2.2kN, the coefficient of friction between rope and pulley is 0.3. Determine the number of ropes required. If the overhung of the pulley is 0.5m, suggest suitable size for the pulley shaft if it is made of steel with a shear stress of 40MPa. [4+12]

7. (a) Explain the distribution of radial and axial pressure in case of hydrodynamic bearing by drawing a neat sketch.

(b) A journal bearing 0.15m in diameter and 0.225m long carries a radial load of 900N at 1200rev/min. The diametral clearance is 0.075mm. Find the viscosity of the oil being used at the operating temperature if 1.5kW is being wasted in friction. [6+10]

8. A screw jack suitable to lift a maximum load of 100kN through a height of 400mm with a ground clearance of 600mm is to be designed with the following:

Allowable stresses for screw:

Tensile stress = 90 N/mm^2

Compressive stress = 110 N/mm^2

Shearing stress = 60 N/mm^2

Allowable stresses for nut:

Tensile stress = 60 N/mm^2

Compressive stress = 50 N/mm^2

Shearing stress = 45 N/mm^2

Allowable bearing pressure between nut and screw is 16 N/mm^2 , Coefficient of

Code No: 07A6EC05

R07

Set No. 4

friction of threads and collar may be taken as 0.14. allowable bending stress for MS handle is 100 N/mm^2 . Design the following:

- (a) Screw
- (b) Nut
- (c) Handle.

[16]

FIRSTRANKER

Code No: 07A6EC05

R07**Set No. 1**

III B.Tech II Semester Examinations, APRIL 2011

DESIGN OF MACHINE MEMBERS-II

Common to Mechanical Engineering, Production Engineering

Time: 3 hours

Max Marks: 80

Answer any FIVE Questions

All Questions carry equal marks

1. An open ring having T-Section as shown in figure 1 is subjected to a compressive load of 130 kN. Determine the stresses at A & B. [16]

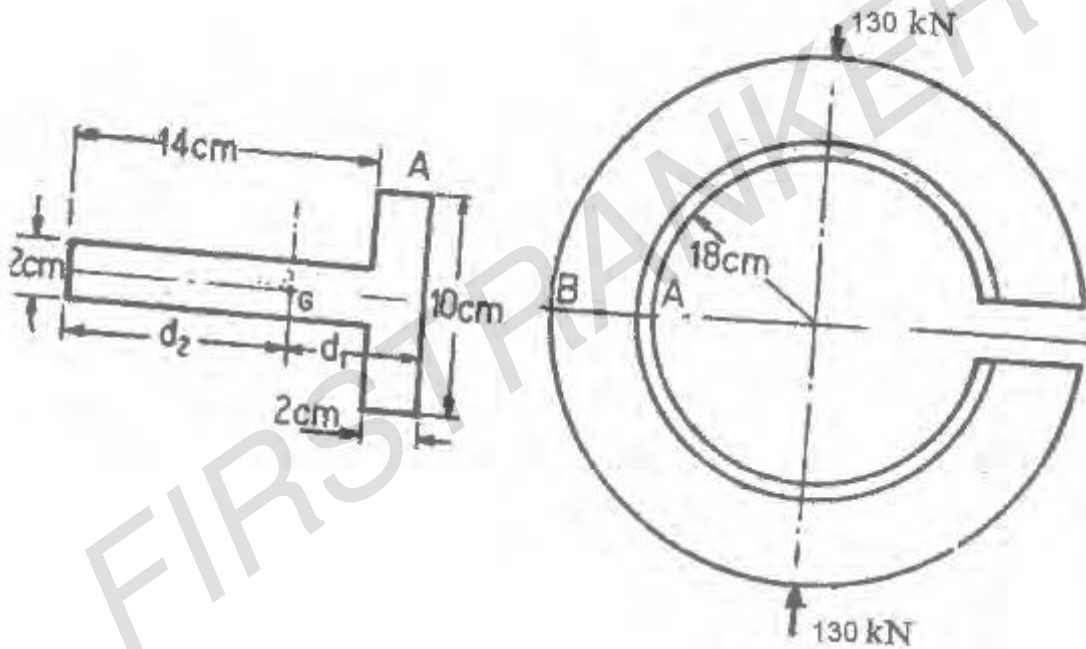

Figure 1

2. Design completely a connecting rod, the bolts for the big end cap for a medium speed, four cylinders I.C. Engine, given the following data:
 Piston diameter = 100mm
 Stroke = 125mm
 Weight of reciprocating parts = 1.1kg
 Length of the connecting rod = 313cm
 RPM of the engine-normal = 1200
 RPM of the engine-over speed = 2000
 Maximum explosion pressure = 2.8MPa
 State clearly the values adopted for the factors of safety and the ultimate stresses and underline them. Draw freehand sketch to about full size, a proportionate elevation of the connecting rod and add either an end view or a sectional plan. [16]
3. (a) How does the helix angle influence the efficiency of square threaded screw?

Code No: 07A6EC05

R07**Set No. 1**

- (b) A 60mm triple start square thread with 10mm pitch, is used with a collar having 30mm inner diameter and 100mm outer diameter. The coefficient of friction at the thread surface and the collar surface may be taken as 0.15. If the screw is required to be used to raise a load of 20kN, using uniform wear theory for the collar friction, determine,
- the torque required to raise the load
 - the torque required to lower the load and
 - the force required to raise the load, if it is applied at a radius of 600mm.
- [4+12]
4. A journal bearing with a diameter of 200mm and length 150mm carries a load of 20kN, when the journal speed is 150r.p.m. The diametral clearance ratio is 0.0015. If possible, the bearing is to operate at 35°C ambient temperature without external cooling with a maximum oil temperature of 90°C. If external cooling is required, it is to be as little as possible to minimize the required oil flow rate and heat exchanger size.
- What type of oil do you recommend?
 - Will the bearing operate without external cooling?
 - If the bearing operates without external cooling, determine the operating oil temperature.
 - If the bearing operates with external cooling, determine the amount of oil in kg/min required to carry away the excess heat generated over heat dissipated, when the oil temperature rises from 85°C to 90°C, when passing through the bearing.
- [16]
5. Design a belt drive pulley for transmitting 10kW at 180 rpm. The velocity of the belt is not to exceed 10m/s, and the maximum tension is not to exceed 15N/mm width. The tension on the slack side is one half of that on the tight side. Determine all the principal dimensions of the pulley.
- [16]
6. Design a piston for four stroke single acting engine developing 90bhp per cylinder when running at 700 rpm.
- The following data are given
- maximum gas pressure = 57kg/mm²
- Average mean effective pressure = 6.4 kg/mm²
- specific fuel consumption = 0.218kg/bhp/hr.
- calorific value of fuel = 10,554kcal/kg.
- Take allowable stresses as 334kg/cm² piston, 800kg/cm² for piston rings and piston pin, and allowable bearing pressure in gudgeon pin is 170kg/cm².
- Assume 5% of the total heat generated to be absorbed by the piston head and thermal heat conductivity for cast iron as 0.393kcal /cm/hour/⁰C.
- Temperature at the centre and at the edges may be assumed approximately 350⁰C and 150⁰C respectively. Mechanical efficiency is 85%; the ratio l/r =4 and radius of crank is 11cm. Allowable bearing pressure on the piston barrel is not to exceed 4 kg/mm².
- [16]

Code No: 07A6EC05

R07

Set No. 1

7. A pair of helical gears consists of a 20 teeth pinion meshing with a 100 teeth gear. The pinion rotates at 720 r.p.m. The normal pressure angle is 20° while the helix angle is 25° . The face width is 40 mm and the normal module is 4mm. The pinion as well as the gear are made of steel having ultimate strength of 600MPa and heat treated to a surface hardness of 300B.H.N. The service factor and factor of safety are 1.5 and 2 respectively. Assume that the velocity factor accounts for the dynamic load and calculate the power transmitting capacity of the gears. [16]
8. (a) A bed subjected to torsional loading is constructed as a closed box type structure while a bed subjected to bending is constructed as an I section. Why? Give mathematical proof to support your conclusion.
- (b) A 2m long, 1m high and 0.5m wide lathe bed consists of two vertical walls strengthened by perpendicular or diagonal stiffeners. The thickness of the walls is 50mm, while that of the stiffeners is 25mm. Calculate the reduced bending rigidity of the beds having perpendicular and diagonal stiffeners. [6+10]

FIRSTRANKER

Code No: 07A6EC05

R07**Set No. 3**

III B.Tech II Semester Examinations, APRIL 2011

DESIGN OF MACHINE MEMBERS-II

Common to Mechanical Engineering, Production Engineering

Time: 3 hours

Max Marks: 80

Answer any FIVE Questions

All Questions carry equal marks

1. Two parallel shafts are connected by a pair of steel helical gears. The power transmitted is 15kW at 4000rpm of the pinion. The safe static strength for the material is 100MPa. Gear ratio is 4:1 Stub teeth with 20° pressure angle in diameter plane have helix angle of 45° . Calculate the necessary BHN with the standard point of wear. Check the design for dynamic load and suggest modification if necessary. Use 30 teeth on the pinion. [16]
2. (a) What are the dimensionless parameters used in designing hydrodynamic bearing? Explain their significance
(b) A 3 kN load is supported by a journal bearing of 75mm dia and 75mm long. Diametral clearance 0.05 mm and the bearing is lubricated by an oil of 0.0207 Pa S viscosity at operating temperature. Determine the maximum speed of rotation of bearing when it is capable of dissipating 80 watts by heat transfer. [6+10]
3. Design an overhang crankshaft with two main bearings for an I.C engine with the following data:
Cylinder bore = 250mm
Stroke length = 300mm
Flywheel weight = 27kN
Maximum pressure = 2.5N/mm^2
Maximum torque at crank rotation 30° and the pressure at that instant = 1.7N/mm^2 . [16]
4. (a) How do you compare the Square and Trapezoidal threads.
(b) What force will be required at a radius of 80mm to raise and lower a 11kN cross bar of a planer? The bar is raised and lowered by two 38mm square thread screws, having a pitch of 7mm. The screw is of steel and nut is of bronze 38mm thick. The collar is of steel and it has an outside diameter of 76mm and inside diameter of 38mm. Assume the coefficient of friction at the threads as 0.11 and at the collar as 0.13. [4+12]
5. Starting from fundamentals, derive an expression for the radius of neutral axis of a T-section curved beam. [16]
6. A V-belt drive is to be transmit 14.7 kW to a compressor. The motor speed is 1150rev/min and the compressor pulley runs at 400rev/min. Determine the size and number of belts required. [16]

Code No: 07A6EC05

R07

Set No. 3

7. (a) What kind of engines are employed in the following applications?
- Air craft
 - Automobile
 - Compressor
 - Motor cycle
- (b) Design a piston, piston rings and gudgeon pin for a single stroke engine for the following given data :
- Cylinder bore = 100mm
Stroke = 120mm
Maximum gas pressure = 7MPa
b.m.e.p = 0.8MPa
Fuel consumption = 0.16kg/brake kW/hr
Speed = 1000rpm. [16]
8. A lathe has two flat, CI slide ways of equal width and height half the width. While turning a 200 mm diameter work piece, the tangential, radial and axial components of the cutting force were found to be $P_x=1400\text{N}$, $P_y=1600\text{N}$ and $P_z=5000\text{N}$ respectively. Calculate the lathe slide ways width assuming suitable values. Cast iron slide ways can with stand a maximum pressure of 2500 kN/m^2 . [16]
