

**II B.TECH - I SEMESTER EXAMINATIONS – MAY, 2011**  
**MECHANICS OF SOLIDS**  
 (COMMON TO ME, MCT, MMT, AE, AME)

Time: 3hours

Max. Marks: 75

Answer any FIVE questions  
 All Questions Carry Equal Marks

- - -

- 1.a) What is ductility of a material? Is ductility a desirable property of constructional material? Explain with reasons.
- b) A rope comprising three 3.0 mm diameter wires clamped together at the ends lifts a load of 15.0 kN. The lengths of the wires are 10.0 m, 10.01 m and 10.02 m. Compute the stresses in each wire. What is the maximum load the rope can lift, if the working stress is limited to 800.0 MPa and the deformation of the rope to 40.0 mm? Assume  $E = 210.0$  GPa. [8+7]

- 2.a) Develop Bending moment and Shear force for the Figure 1 given below indicating the maximum and minimum values.

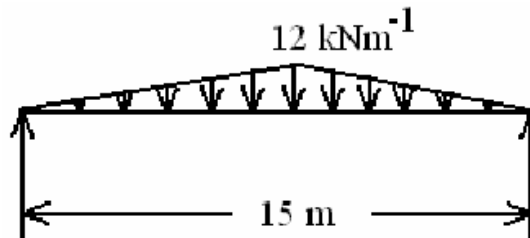

Figure 1

- b) Develop Bending moment and Shear force for the Figure 2 given below indicating the maximum and minimum values. [8+7]

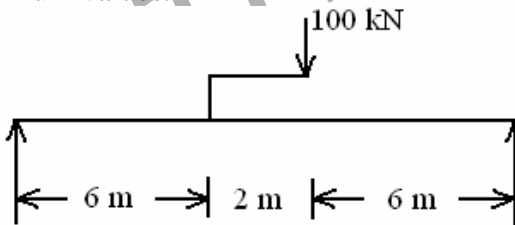

Figure 2

3. A cantilever beam, 60 mm wide by 200 mm high and 6 m long, carries a load that varies uniformly from zero at the free end to 1000 N/m at the wall.
- a) Compute the magnitude and location of the maximum flexural stress.
- b) Determine the type and magnitude of the stress in a fiber 40 mm from the top of the beam at a section 3 m from the free end. [8+7]
4. Develop the shear stress distribution diagrams for the sections shown for the following Figure 3 when subjected to a transverse S.F. of 200.0 kN. What are the maximum shear stresses? [15]

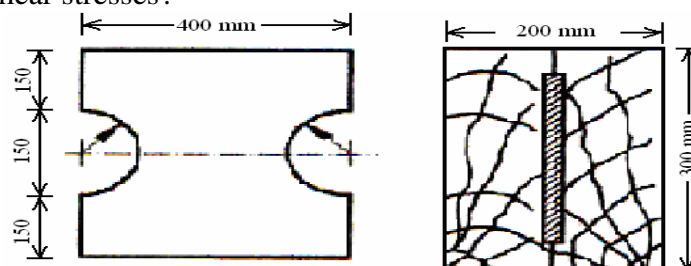

Figure 3

5. Analyze the truss indicated in Figure 4 by method of sections. [15]

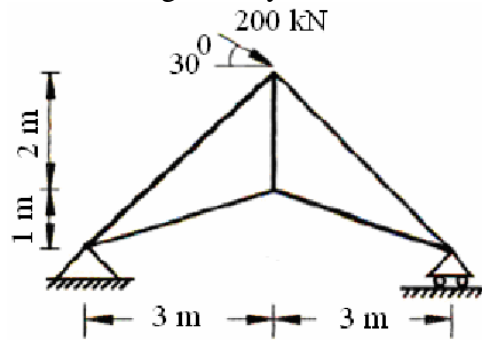

Figure 4

6. Compute the maximum deflections and support rotations in the beams of the following Figure 5 using  
 a) The methods of integration  
 b) The method of moment area. [15]

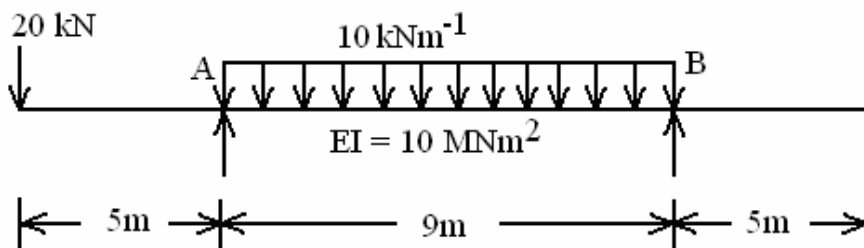

Figure 5

7. A cylinder boiler of diameter 1.7 m, 4.5 m length and 10 mm thickness with flat ends is provided with six tie rods of 40 mm diameter. If the tie rods are stressed initially to 82.0 MPa, determine the stresses in the tie rods and the cylinder under a pressure of 1.8 MPa. Assume the same material for the boiler and tie rods. [15]
8. A compound cylinder comprises an inner tube of diameters 100.0 mm and 140.0 mm, and an outer tube of diameters 140.0 mm and 180.0 mm. determine the diametral interference required so that the final maximum stress in the tube does not exceed 120.0 MPa under an internal pressure of 45.0 MPa. Neglect the effects of longitudinal stresses. Assume  $E = 120.0 \text{ GPa}$ . [15]

\*\*\*\*\*

**II B.TECH - I SEMESTER EXAMINATIONS – MAY, 2011**  
**MECHANICS OF SOLIDS**  
 (COMMON TO ME, MCT, MMT, AE, AME)

Time: 3hours

Max. Marks: 75

Answer any FIVE questions  
 All Questions Carry Equal Marks

- - -

- 1.a) Explain the concept of factor of safety and its significance in the design of machine components? What is working stress of a material?  
 b) A prismatic member of length  $l$  and unit weight  $w$  is suspended freely from its end. Determine the elongation of the member under gravity. [8+7]

- 2.a) Develop Bending moment and Shear force for the Figure 1 given below indicating the maximum and minimum values.

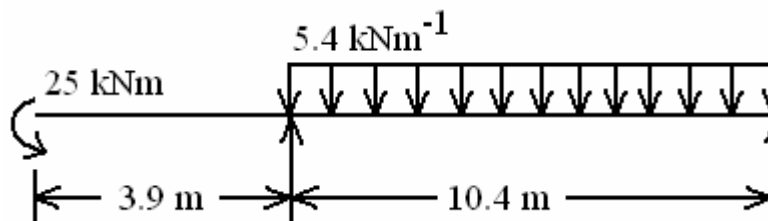

Figure 1

- b) Develop Bending moment and Shear force for the Figure 2 given below indicating the maximum and minimum values. [8+7]

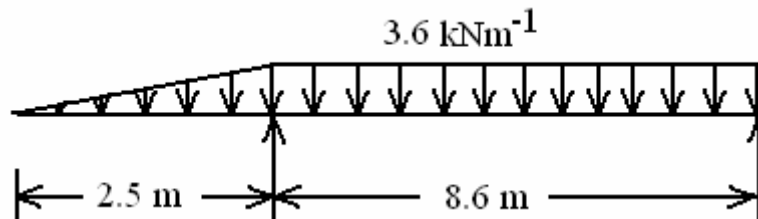

Figure 2

3. A flat steel bar, 25 mm wide by 6 mm thick and 1 m long, bent by couples applied at the ends so that the midpoint deflection is 20 mm. Compute the maximum stress in the bar and the magnitude the couples. Use  $E = 200 \text{ GN/m}^2$ . [15]  
 4. Develop the shear stress distribution diagrams for the sections shown for the following Figure 3 when subjected to a transverse S.F. of 200.0 kN. What are the maximum shear stresses? [15]

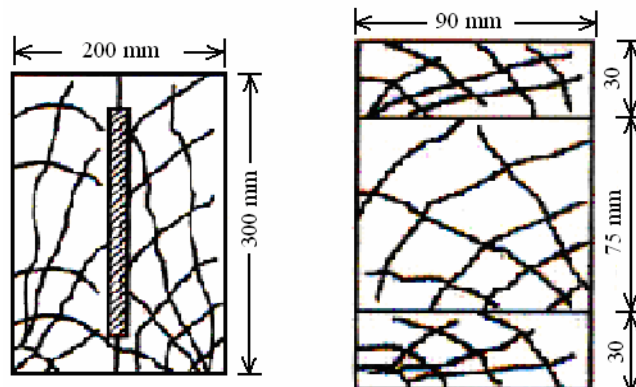

Figure 3

- 5.a) Explain the advantages of trusses, indicating various truss configurations and their economical span ranges.
- b) What is degree of indeterminacy in trusses? Explain with examples. [8+7]
6. Compute the maximum deflections and support rotations in the beams of the following Figure 4 using
- a) The methods of integration
- b) The method of moment area. [15]

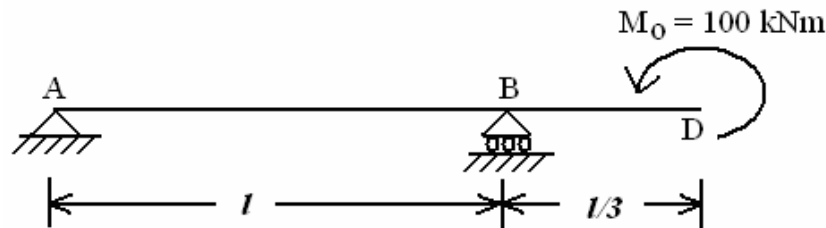

Figure 4

7. A mild steel pipeline of 550.0 mm diameter and 5 mm thickness is subjected to an internal water pressure of 1.1MPa. The pipeline is subjected to a torque of 70.0 kNm as well. Determine the design stresses in the pipeline. [15]
8. Design a cylinder of 800.0 mm inner diameter to sustain an internal pressure of 5.0 MPa. Assume  $E = 30.0 \text{ GPa}$  and a safe stress of 15.0 MPa. [15]

\*\*\*\*\*

FIRSTRANKER

**II B.TECH - I SEMESTER EXAMINATIONS – MAY, 2011**  
**MECHANICS OF SOLIDS**  
 (COMMON TO ME, MCT, MMT, AE, AME)

Time: 3hours

Max. Marks: 75

Answer any FIVE questions  
 All Questions Carry Equal Marks

- - -

- 1.a) Describe the effects of temperature changes when a body is  
 i) Free to deform and  
 ii) Restrained.
- b) A concrete column is reinforced with steel bars comprising 6 percent of the gross area of column section. What is the fraction of the compressive load sustained by steel bars, if the ratio of Young's moduli of steel and concrete is 12.5? [8+7]
- 2.a) Develop Bending moment and Shear force for the Figure 1 given below indicating the maximum and minimum values.

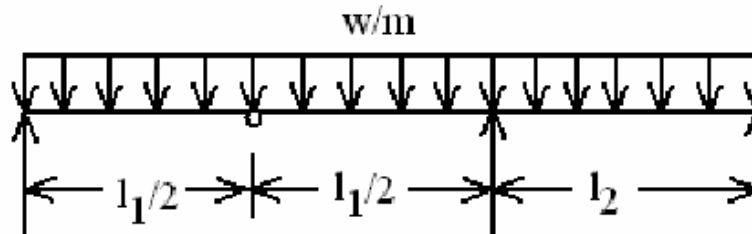

Figure 1

- b) Develop Bending moment and Shear force for the Figure 2 given below indicating the maximum and minimum values. [8+7]

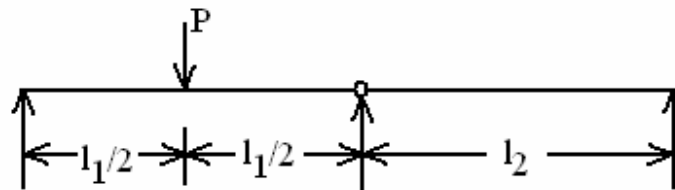

Figure 2

3. In a laboratory test of a beam loaded by end couples, the fibers at layer AB in as shown in Figure 3 are found to increase  $30 \times 10^{-3}$  mm while those at CD decrease  $90 \times 10^{-3}$  mm in the 200 mm gauge length. Using  $E = 100$  GPa, determine the flexural stress in the top and bottom fibers. [15]

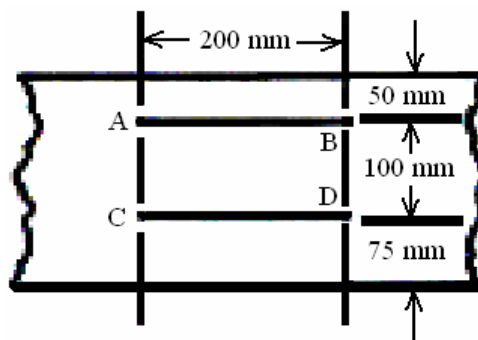

Figure 3

4. Show that the maximum shearing stress in a beam having a thin-walled tubular section of net area  $A$  is  $\tau = \frac{2V}{A}$ . [15]

5. Analyze the truss indicated in Figure 4 by method of sections. [15]

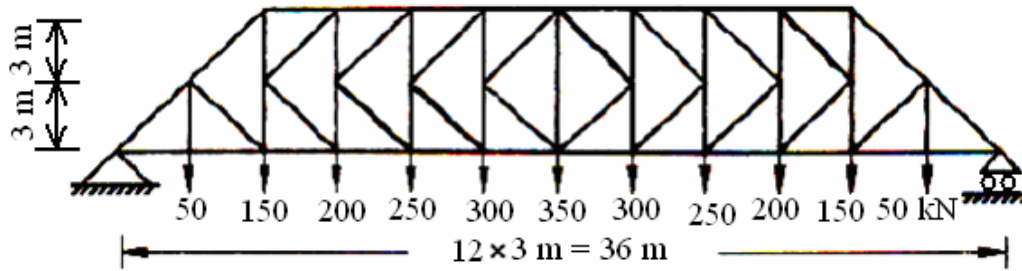

Figure 4

- 6.a) Determine the maximum deflection  $\delta$  in a simply supported beam of length  $L$  carrying a concentrated load of  $P$  at  $1/4$  of the span from left hand side.
- b) Determine the maximum deflection  $\delta$  in a simply supported beam of length  $L$  carrying a uniformly distributed load from center of the beam to left hand support. [8+7]
7. A cast iron pipe of 200.0 mm diameter and 6 mm thickness carries water at a head of 27.0 m. Determine the maximum allowable spacing of supports, if the yield strength of the material is 180.0 MPa. Use a factor of safety of 1.8. [15]
8. The outer diameter of a cylinder is 1.8 times its inner diameter. Assuming  $E = 0.25$ , determine the ratio of external and internal pressures applied separately, so that in both the cases
- a) The largest stresses have the same numerical values and
- b) The largest strains have the same numerical values. [15]

\*\*\*\*\*

**II B.TECH - I SEMESTER EXAMINATIONS – MAY, 2011**  
**MECHANICS OF SOLIDS**  
 (COMMON TO ME, MCT, MMT, AE , AME)

Time: 3hours

Max. Marks: 75

Answer any FIVE questions  
 All Questions Carry Equal Marks

- - -

- 1.a) State the principle of superposition, and explain its significance.  
 b) A weight of 500 N falls on the collar of a 20 mm diameter steel bar from a height of 100.0 mm. Investigate whether the bar can withstand the load. Assume a yield stress of 275.0 MPa, a fracture strain of 24.5 percent and  $E = 195.0$  GPa for steel. [8+7]
- 2.a) The following Figure 1 indicates the Shear Force diagram. Develop the loading and Bending Moment diagram for the beam.

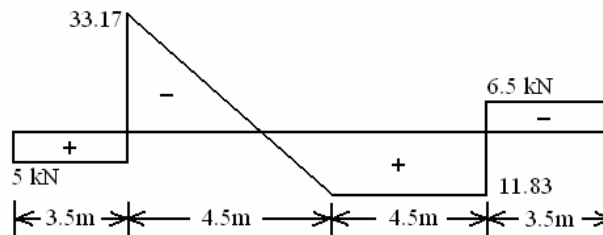

Figure 1

- b) The following Figure 2 indicates the Shear Force diagram. Develop the loading and Bending Moment diagram for the beam. [8+7]

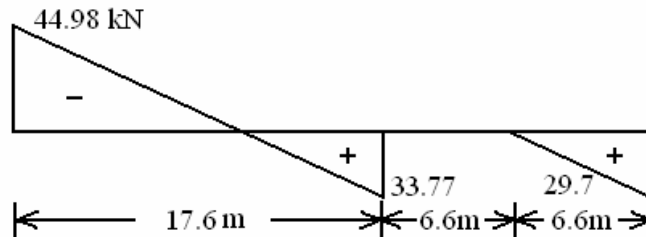

Figure 2

3. Determine the moment capacity of a timber beam of section  $50.0 \times 120.0$  mm with an allowable stress of 8.5 MPa and  $E = 16.0$  GPa. Determine the size of 2.0 mm thick steel flitches required to double its moment capacity when the flitches are attached  
 a) at top and bottom  
 b) to the sides ( $E_s = 200.0$  GPa). [15]
4. A plywood beam is built up of 6-mm strips separated by blocks as shown in Figure 3. What shearing force  $V$  will cause a maximum shearing stress of 1.4 MPa? [15]

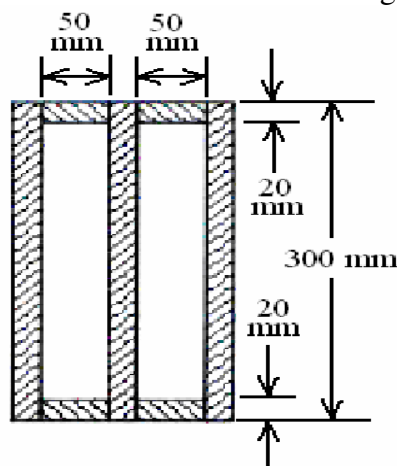

Figure 3

5. Analyze the truss indicated in the Figure 4 by method of joints. [15]

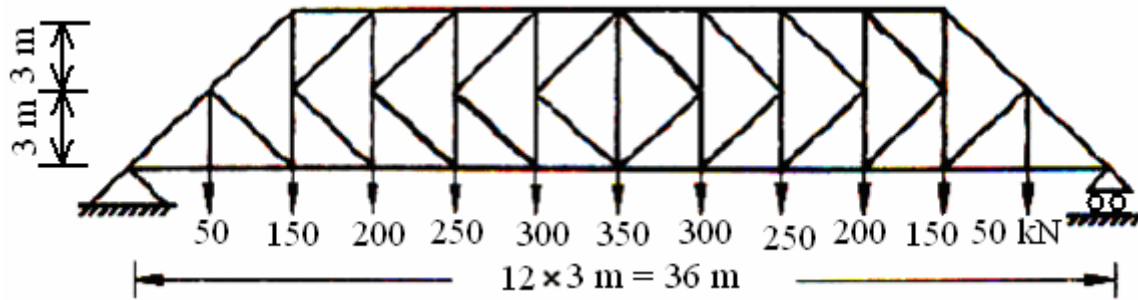

Figure 4

- 6.a) Determine the maximum deflection  $\delta$  in a simply supported beam of length  $L$  carrying a concentrated load of  $P$  at  $1/4$  of the span from right hand side and also carrying a uniformly distributed load for the entire span.
- b) Determine the maximum deflection  $\delta$  in a simply supported beam of length  $L$  carrying a uniformly distributed load from center of the beam to right hand support. [8+7]
7. A concrete pipe of radius 1.1m and 110.0 mm wall thickness is pre-stressed by a wire 5.0 mm diameter to withstand a working pressure of 1.0MPa. Determine the minimum initial stress required in the wire so that the pipe is not subjected to tensile stresses under the applied pressure. Assume  $E_c = 30.0$  GPa, and  $E_s = 200.0$ GPa. [15]
8. A cast iron hub of 300.0 mm external diameter and 70.0 mm thickness is pressed on to a steel shaft of 125.0 mm diameter. Determine the radial stress required at the interface so that the shaft can transmit 4.0 MW at 740 rpm. Compute the necessary diametral interference and the stresses in the shaft and the hub. If the shaft is subjected to a compressive force of 300.0 kN, find the change in the stresses. Assume a frictional coefficient of 0.29, Poisson's ratio of 0.22, and Young's moduli of steel and cast iron to be 210.0 GPa and 180.0 GPa, respectively. [15]

\*\*\*\*\*