

II B.TECH - II SEMESTER EXAMINATIONS, APRIL/MAY, 2011
PRINCIPLES OF ELECTRICAL ENGINEERING
(COMMON TO ELECTRICAL AND COMMUNICATION ENGINEERING &
ELECTRONICS AND TELEMATICS ENGINEERING)

Time: 3hours

Max. Marks: 75

Answer any FIVE questions
 All Questions Carry Equal Marks

- - -

- 1.a) For the circuit shown below Figure. 1, find the current equation when switch S is opened at $t = 0$.

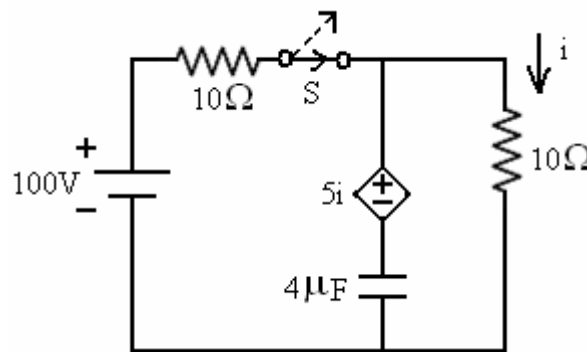

Figure. 1

- b) Convert the current source shown below Figure. 2 in to a voltage source in the S domains. [7+8]

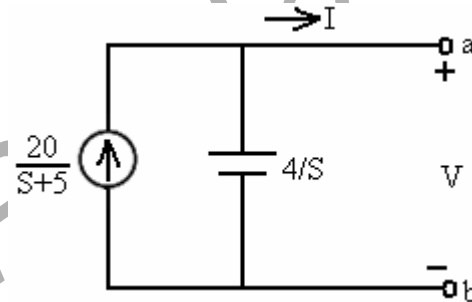

Figure. 2

2. Find Z and Y parameter of the network shown below Figure. 3. [15]

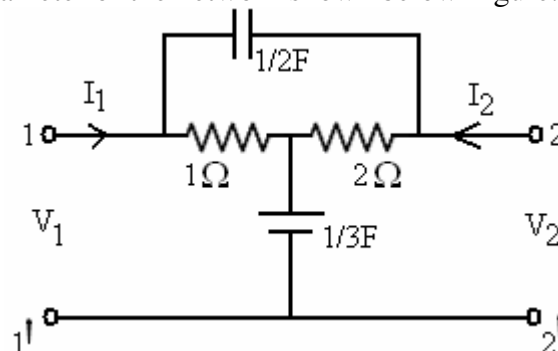

Figure. 3

3. Design a band elimination filter having a design impedance of 600Ω and cut – off frequencies $f_1 = 2$ KHZ and $f_2 = 6$ KHZ. [15]

4. Explain T – type attenuator and also design a T – type attenuator to give an attenuation of 60dB and to work in a line of 500Ω impedance. [15]
5. What are the different types of dc generators? Show the connection diagrams and load characteristics of each type. [15]
- 6.a) Explain why a dc series motor should never run unloaded.
b) A 200V, 14.92kW, dc shunt motor when tested by Swinburne's method gave the following test results.
Running light: Armature current of 6.5 A and field current = 2.2A
With armature locked: $I_a=70A$ when potential difference of 3V was applied to the brusher.
Estimate efficiency of motor when working under full load. [5+10]
7. A 50Hz, 1 \emptyset , 100 KVA transformer has full load copper loss of 1200W and its iron loss is 960W. Calculate:
a) The efficiency at full load, unity power factor.
b) The efficiency at half load, 0.8 power factor.
c) The efficiency at 7.5% of full load, 0.7 power factor. [15]
8. Write short notes on the following:
a) AC Servo motors.
b) Shaded pole motor.
c) Synchronos. [15]

II B.TECH - II SEMESTER EXAMINATIONS, APRIL/MAY, 2011
PRINCIPLES OF ELECTRICAL ENGINEERING
(COMMON TO ELECTRICAL AND COMMUNICATION ENGINEERING &
ELECTRONICS AND TELEMATICS ENGINEERING)

Time: 3hours

Max. Marks: 75

Answer any FIVE questions
 All Questions Carry Equal Marks

- - -

- 1.a) For the below circuit (Figure.1), find the current in 20Ω when the switch is opened at $t = 0$.

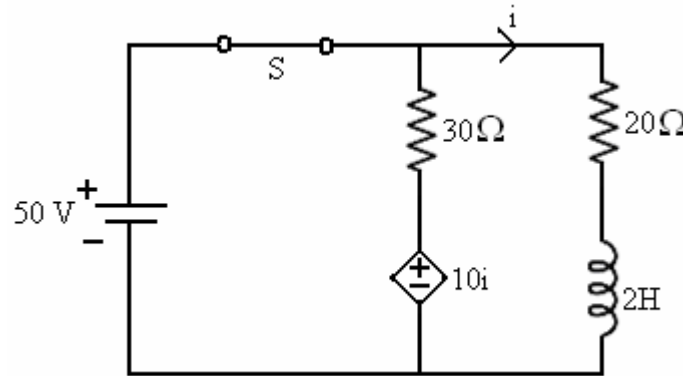

Figure. 1

- b) Transform the below circuit (Figure. 2) into 'S' domain and determine the Laplace transform impedance. [7+8]

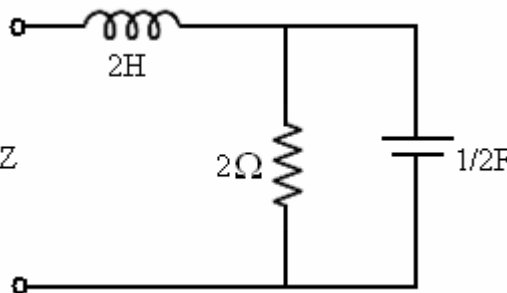

Figure. 2

2. Determine Y – parameters of the below (Figure. 3) network. Hence determine the h-parameters. [15]

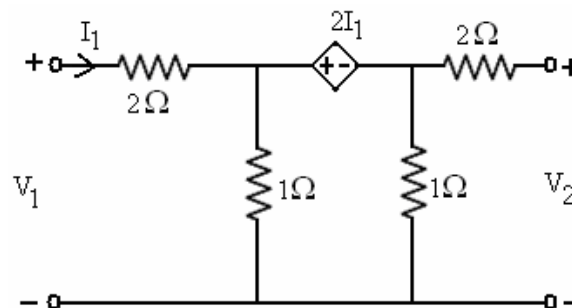

Figure. 3

3. Design a m – derived high pass filter with a cut – off frequency of 10KHz; design impedance of 5Ω and $m = 0.4$. [15]

4. Explain the lattice attenuator and also design a lattice attenuator to have a characteristic impedance of 800Ω and attenuation of 20 dB. [15]
5. State the principle of operation of a dc generator and derive the expression for the emf generated. [15]
- 6.a) Derive the torque equation of a dc motor.
b) A 4 pole, 500V dc shunt motor has 700 wave connected armature conductors. The full load armature current is 60 A and the flux per pole is 30mWb. Calculate the full load speed if the motor armature resistance is 0.2Ω and brush drop is 1V per brush. [7+8]
7. Draw the phasor diagram of a single phase transformer under load conditions for lagging, leading and unity power factors. [15]
8. Explain in detail the principle of operation and constructional details of a shaded pole motor. [15]

FIRSTRANKER

II B.TECH - II SEMESTER EXAMINATIONS, APRIL/MAY, 2011
PRINCIPLES OF ELECTRICAL ENGINEERING
(COMMON TO ELECTRICAL AND COMMUNICATION ENGINEERING &
ELECTRONICS AND TELEMATICS ENGINEERING)

Time: 3hours

Max. Marks: 75

Answer any FIVE questions
 All Questions Carry Equal Marks

- 1.a) For the below circuit (Figure. 1), find the current equation $i(t)$, when the switch is opened at $t = 0$.

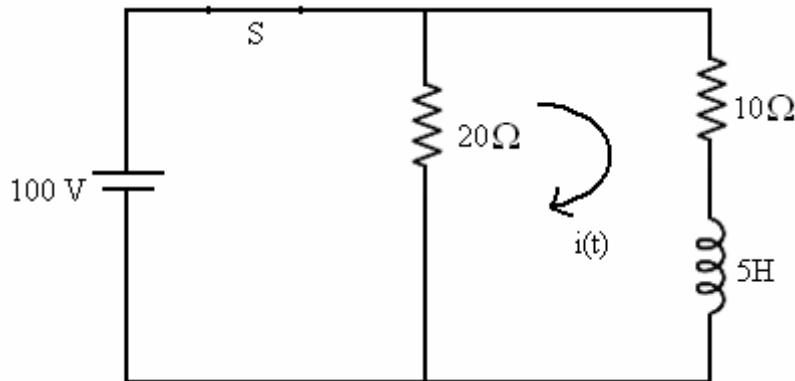

Figure. 1

- b) Transform the below circuit (Figure.2) in to 'S' domain and determine the laplace impedance. [7+8]

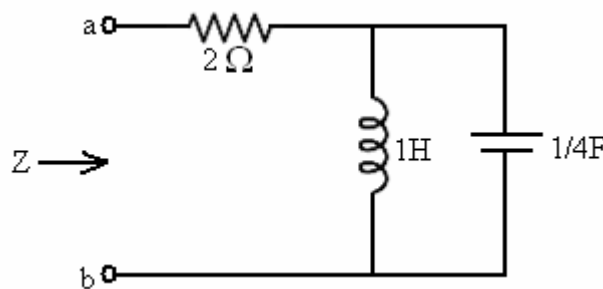

Figure. 2

2. Determine the transmission parameter and hence determine the short circuit admittance parameters for the below circuit (Figure.3). [15]

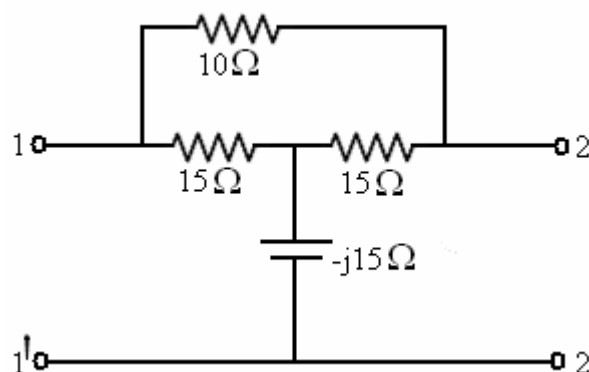

Figure. 3

3. What is a constant – K low pass filter, derive its characteristics impedance. [15]

4. Explain π – type attenuator and also design it to give 20db attenuation and to have characteristic impedance of 100Ω . [15]
5. Explain in detail the construction and principle of operations of DC generators. [15]
6. Discuss in detail the different methods of speed control of a dc motor. [15]
7. Open circuit and short circuit tests on a 5 KVA, 220/400V, 50 Hz, single phase transformer gave the following results:
OC Test: 220V, 2A, 100W (lv side)
SC Test: 40V, 11.4A, 200W (hv side)
Determine the efficiency and approximate regulation at full load, 0.9 power factor lagging. [15]
8. Write a short note on the following:
a) Capacitor motors.
b) Stepper motor.
c) AC tachometers. [15]

FIRSTRANKER

II B.TECH - II SEMESTER EXAMINATIONS, APRIL/MAY, 2011
PRINCIPLES OF ELECTRICAL ENGINEERING
(COMMON TO ELECTRICAL AND COMMUNICATION ENGINEERING &
ELECTRONICS AND TELEMATICS ENGINEERING)

Time: 3hours

Max. Marks: 75

Answer any FIVE questions
 All Questions Carry Equal Marks

- - -

- 1.a) Determine the current i for $t \geq 0$ if initial current $i(0) = 1$ for the below circuit (Figure. 1).

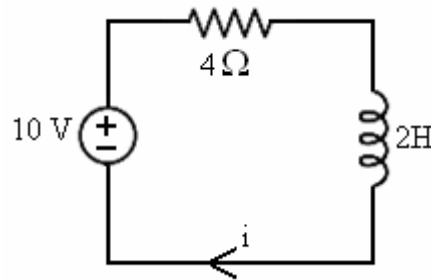

Figure. 1

- b) Switch is opened at $t = 0$ in the below circuit (Figure. 2). Then find the current 'i'. [7+8]

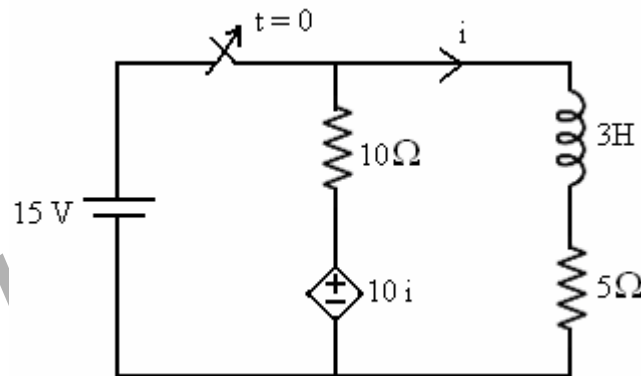

Figure. 2

2. Obtain Z parameters of the below circuit (Figure. 3) and from there Z – parameters derive h – parameters. [15]

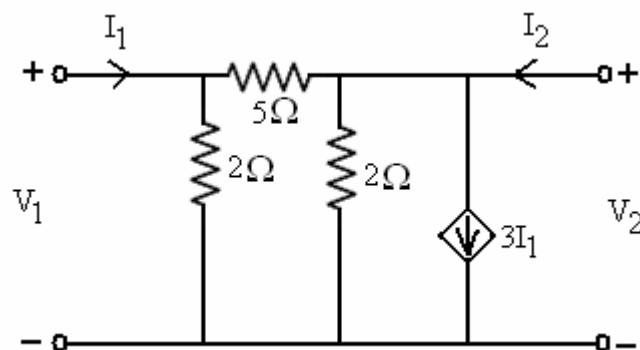

Figure. 3

3. A low pass π section filter consists of an inductance of 25 mH in series arm and two capacitors of $0.2\mu\text{F}$ in shunt arms. Calculate the cut – off frequency, design impedance, attenuation at 5 KHz and phase shift at 2 KHz. Also find the characteristic impedance at 2 KHz. [15]
4. Explain Bridged – T attenuator and also design it with an attenuation of 20 dB and terminated in a load of 500Ω . [15]
5. A 6 – pole dc shunt generator with a wave – wound armature has 960 conductors. It runs at a speed of 500 rpm. A load of 20Ω is connected to the generator at a terminal voltage of 240V. The armature and field resistances are 0.3Ω and 240Ω respectively. Find the armature current, the induced emf and flux per pole. [15]
6. Sketch the speed – load characteristics of a dc shunt, series and compound motors. Account for the shape of the above characteristic curves. [15]
- 7.a) Derive the expression for the induced emf of a transformer.
b) A 125 KVA transformer having primary voltage of 2000V at 50 Hz has 182 primary and 40 secondary turns. Neglecting losses, calculate:
 - i) The full load primary and secondary currents.
 - ii) The no-load secondary induced emf.
 - iii) Maximum flux in the core. [7+8]
8. Draw the circuit diagram of capacitor – start, capacitor – run single phase induction motor and explain its working. Where this type of motor is commonly used? [15]
